

# MANUAL COVER

We at Larry Hess & Associates, Inc. would like to take this opportunity to thank you for your patronage. The machine you have purchased has been manufactured and assembled in the USA with quality materials by skilled craftsmen, backed by a highly qualified engineering staff. Your machine has passed a Quality Assurance test that enables you to begin enjoying benefits of your machine right away.

Provided in this manual are operating instructions, a trouble shooting guide, maintenance procedure and detailed parts listings. In the event you have any problems or questions pertaining to your machine, please contact our Service Department.

To expedite parts ordering or technical questions, please include your Model and Serial Number listed below in all correspondence.

<b>MACHINE MODEL NUMBER:</b>	
<b>SERIAL NUMBER:</b>	
<b>DATE OF MANUFACTURE:</b>	

## **OPTIONS INCLUDED:**

<b>PART NUMBER</b>	<b>DESCRIPTION OF OPTION</b>

## **WARNING**

DO NOT USE **SAND**. *SAND WILL CAUSE SILICA DUST, WHICH IS THE CAUSE OF SILICOSIS DISEASE, A CONDITION OF MASSIVE FIBROSIS OF THE LUNGS.* THIS STATEMENT INDICATES POTENTIAL PERSONNEL HAZARD. FAILURE TO COMPLY WITH THESE INSTRUCTIONS MAY RESULT IN PERSONAL INJURY.

**LARRY HESS AND ASSOCIATES, INC**  
185 PIPER LANE / SALISBURY, NC 28147  
PHONE: 1-800-535-2612 / FAX: 1-704-638-9311  
WWW.BLAST-IT-ALL.COM

## **BLAST-IT-ALL® SUCTION BLAST CABINET**

NOTE: It is the responsibility of the user to read and understand this manual and to provide a safe work environment for any operator. No representation is intended as to the suitability of this equipment for any specific application. Media selection and production rates are the sole responsibility of the end user. The user takes full responsibility to insure compliance with regulations and safe operation on this equipment.



***DO NOT USE SAND. SAND WILL CAUSE SILICA DUST, WHICH IS THE CAUSE OF SILICOSIS DISEASE, A CONDITION OF MASSIVE FIBROSIS OF THE LUNGS. THIS STATEMENT INDICATES POTENTIAL PERSONNEL HAZARD. FAILURE TO COMPLY WITH THESE INSTRUCTIONS MAY RESULT IN PERSONAL INJURY.***

**WEBSITE CONCERNING SILICOSIS:**  
[http://www.osha.gov/Silica/TT69D\\_1.html](http://www.osha.gov/Silica/TT69D_1.html)

MANUAL NUMBER: (668)    DATE IF ISSUE: AUGUST 2009

# TABLE OF CONTENTS

## SECTIONS

		<b>PAGES</b>
SECTION I	GENERAL INFORMATION	1
SECTION II	UTILITY REQUIREMENTS	2
SECTION III	INSTALLATION	3-5
SECTION IV	MAINTENANCE	6
SECTION V	BLAST GUN	7
SECTION VI	RECLAIMER - AIR WASH	8
SECTION VII	DUST COLLECTOR	9-10
SECTION VIII	SAFETY BLAST CONTROLS	10
SECTION IX	TROUBLE SHOOTING	11-12

## DRAWINGS

<b>NUMBER</b>	<b>DESCRIPTION</b>	<b>PAGES</b>
M117	MACHINE FRONT	13
M129	LIGHT BOX	14
A7232	AIR CONTROLS	15
A7230	AIR CONTROL ASSEMBLY	15A
M9009	BLAST GUN	16
M1005	RECLAIM 400 CFM	17
M1115	RECLAIM 700 CFM	18
M1211	RECLAIM 900 CFM	19
B2129-4	D10 (400 CFM) DUST COLLECTOR	20
B2129	D10 (700 CFM) DUST COLLECTOR	21
B2131	D20 (900 CFM) DUST COLLECTOR	22
A5107	ELECTRICAL 120V	23
B5102-M	ELECTRICAL 208/230/460V	24

## TABLES

TABLE I	ORIFICE / CFM / PSI	2
TABLE II	RECLAIM / DUST BAGS	3
TABLE III	MEDIA QUANTITY	5

# SECTION I

## DESCRIPTION AND GENERAL INFORMATION

### 1-1 Purpose and Scope

This publication contains operations and maintenance instructions with a trouble shooting guide and illustrated part's breakdown for the Larry Hess & Associates, Inc. Dry Blast Cabinet.

**1-2** The blast cleaning machine is of the enclosed type. Parts for processing are loaded into the cabinet through doors on the right or left side of the cabinet. The operator's hands are inserted into a pair of gloves to protect the operator and to retain the media in the enclosure. Observation of parts in process is through a tempered glass window in the cabinet front. The unit also contains a sealed, two tube, fluorescent light which illuminates the work area. This machine is equipped with a safety interlock which controls the blasting process. This provides a measure of safety for the blast operator.

An externally supplied compressed air pressure propels the media for abrasive blasting cleaning. The air pressure is routed through a moisture separator, pressure regulator, and blast control to the nozzle.

The blast cleaning machine is equipped with a media reclaiming cyclone separator. Media, dust, and debris are returned from the cabinet sump for separation. Reusable material drops through the filter screen where large particles are trapped, and into the storage hopper for reuse. The cyclone separator is equipped with an adjustable slide tube assembly, which controls the amount of dust being removed from the media.

Air and dust exhausted from the cyclone separator may be contained by several means. Standard means is the use of a Dust Bag attached to the outlet of the blower.

**OPTIONAL** Dust collector systems that are offered and easily installed with the machine.

### 1-3 General Information

**This machine is designed primarily for blast cleaning with glass beads, (size 3-13) or aluminum oxide (size 46-220).** Other types and sizes of blast media require special consideration. The nozzle pressure and media is determined by the application.

# **SECTION II**

## **UTILITY REQUIREMENTS**

### **2-1 Air Requirements**

Compressed air with sufficient CFM and pressure must be used. Normal blast pressure should not exceed 80 PSI. Air volume (CFM) must be sufficient to maintain correct blast pressure for the gun orifice used (see Table 1). Compressed air to the dry blast cabinet must be clean and dry. Water and/or oil in the compressed air will contaminate the media and cause clogging in the machine, nozzle, reclaimer and dust collecting system. Piping to the machine should be of the size of the machine inlet or larger to prevent pressure and volume loss.

**TABLE 1**

<b><u>Orifice</u></b>	<b><u>CFM</u></b>	<b><u>PSI</u></b>
No. 4	21.0	80
No. 5	31.0	80
No. 6	47.0	80
No. 7	62.0	80
No. 8	85.0	80

### **2-2 Electrical Requirements**

The standard blast machine is equipped with a cord and plug for 120 Volt, single phase, 60 HZ operation. All other voltages require termination wiring on the machine.

- A.** 1 HP, 120 Volt, 1Phase, 60 HZ, 20 AMP. circuit
- B.** 1 HP, 240 Volt, 1 Phase, 60 HZ, 10 AMP. circuit
- C.** 2 HP, 240 Volt, 1 Phase, 60 HZ, 20 AMP. circuit
- D.** 2 HP, 230 Volt, 3 Phase, 60 HZ, 20 AMP. circuit
- E.** 2 HP, 460 Volt, 3 Phase, 60 HZ, 10 AMP. circuit

Machines that are wired **for other than** 120 Volt, 1 Phase, use a step down transformer to power the lights and control voltage. Make sure machine and components are properly grounded as per local NEC requirements.

# **SECTION III**

## **INSTALLATION - SUCTION MACHINE**

### **3-1 Location**

In selecting a location for your blast cabinet the following should be taken into consideration:

- A.** Access to electrical supply
- B.** Access to compressed air supply
- C.** Sufficient room around machine for parts handling
- D.** Access to dust bag or dust collector for dust removal
- E.** Access to reclaimer fill door to clean trash screen and add media.
- F.** Noise level of blasting operation to other operator stations
- G.** High atmospheric humidity conditions where moisture is pulled into the cabinet

### **3-2 Installation**

- A.** Remove the plastic covering and any strapping holding the machine and components.
- B.** Remove lag bolts holding the machine to the pallet, and remove from pallet. Place the machine in the desired location.
- C.** Remove reclaim system (700 CFM IS ATTACHED TO THE BACK OF THE CABINET) from pallet and place unit behind cabinet.
- D.** Select the proper size flex hose and two (2) clamps to connect reclaimer to the machine. Slide one end of the flex hose on the sump outlet of the machine and clamp in place. Slide the other end of the flex hose onto the reclaimer inlet and clamp in place.
- E.** Connect MEDIA hose to the media valve located on the bottom of the RECLAIM HOPPER.
- F.** **Dust Bag Installation:**

Remove the dust bag from its package and unfold. Slide dust bag opening over the outlet of the blower housing, making sure zippered end is in the down position. Using the proper clamp, secure dust bag to the blower housing.

#### **TABLE 2**

R-14 Reclaimer - 400 CFM	1 Dust Bag (11-415)
R-18 Reclaimer - 700 CFM	1 Dust Bag (11-715)
R-24 Reclaimer - 900 CFM	2 Dust Bags (11-715)

**G. Dust Collector Installation D10 and D20:**

Move the dust collector to a position close to the reclaimer. Slip one end of the flex hose (6 in. for D10(700 CFM), 8 in. for D20(900 CFM) on the outlet adapter located on the top of the reclaimer and clamp in place. Slip the other end of the flex hose on the inlet damper of the dust collector and clamp in place. Connect the 1/4 inch plastic air supply line for the shaker valve to the fitting supplied on the compressed air line. **Be sure the slide gate on the bottom of the Dust Collector sump is in place and closed before starting the machine.**

**H. If machine is wired for other than 120 volt single phase,** wires from the machine should be terminated. **A qualified electrician should connect wiring to the motor. Check side of the motor for correct wiring of desired voltage and wiring schematic.**

**I.** Connect compressed air line to the moisture trap located on the rear of the machine. (See Table 1 for compressed air requirements).

**J.** Connect proper electricity to the machine using motor data plate and Section 2-2 for guidance.

**K.** Connect a grounding conductor to an earth ground.  
**Example:** Cold water pipe, ground rod, etc.

**L.** For machines with a dust collector, loosen the wing nut on the inlet damper handle. Move the handle to 3/4 open position and tighten wing nut to prevent damper from moving.

**M.** Slowly turn on compressed air supply.

**N.** Move switch to the OFF position and apply electrical power to the machine.

**O.** Move the switch to its ON position. The two tube, fluorescent light will illuminate the interior of the cabinet and the blower motor will start.

**P. Single Phase Machines:** Fan rotation has been checked at factory.

**Q. Three Phase Machines:**

Three phase motors must have the rotation of the blower checked before operating. **The fan must turn clockwise in the blower housing viewed from the top, of motor side of the blower housing.** If rotation is wrong, have a qualified electrician reverse rotation. If rotation is correct, press the switch marked Start and machine motor will start.

**R.** Close all doors on the machine and reclaimer. If the machine includes a dust collector, make sure the slide gate has been installed. Insert one hand into a glove and hold the blast nozzle firmly. Activate the blast by pressing down on the foot valve. Observe the reading on the gauge. Adjust the regulator until the gauge reads 80 PSI.

Release the foot valve and blast will stop. Activate and release foot pedal several times to become familiar with the feel of the blast.

- S. Stop the Reclaim Fan before adding media.
- T. Obtain the desired media selected for you operation. Open the reclaim door and pour the correct amount of media into the hopper of the reclaim (See Table 3). Close the reclaim door and secure latch, making sure the reclaim door is sealed.

**Table 3**

400 CFM	10 LBS MEDIA
700 CFM	15 LBS MEDIA
900 CFM	20 LBS MEDIA

- U. Open the machine door and place a test piece, onto the grate within reach of the gloves. Close the machine door and latch securely. Move switch to its ON position. Insert both hands into the gloves. Hold the piece to be blasted **firmly** in one hand, and the blast gun in the other. Activate the foot pedal to begin blasting. **(Do not point GUN at viewing window).**
- V. The blasting technique is similar to spray painting, that is, smooth continuous strokes are most effective. The distance of the GUN from the part affects the size and results of the blast pattern. Normal use places the GUN approximately 6-8 inches from the item, at approximately 30 to 45 degrees. Several media sizes and pressures may be required to process many varied types of materials.
- W. **Dust Removal - Dust Bags:**  
  
Obtain a container and place under the dust bag. Use the zipper in the bottom of the dust bag to open the bag and allow the accumulated dust to flow into the container. When the dust has been transferred into the container, close the dust bag by moving the zipper to its closed position.

**CAUTION: NEVER OPEN DUST BAG WITH MOTOR RUNNING!**

- X. **Dust Removal - Dust Collector:**

**With motor off**, press the button of the air operated vibrator valve mounted on the side of the dust collector. When vibrator valve is activated, you will be able to hear the vibrator shaking the bags inside the dust collector. The vibrator should be activated for one (1) minute before releasing. Obtain a container and place under the slide gate on the sump of the dust collector. **Slowly** move slide gate to its OPEN position and the accumulated dust will flow into the container. When dust has stopped flowing, close the slide gate.

**CAUTION: NEVER ACTIVATE SHAKER OR SLIDE VALVE WITH MOTOR RUNNING**

**Note:** Dust removed from the dust bag or dust collector must be disposed of in an approved manner. This dust is WASTE and should **NEVER BE PUT BACK INTO THE MACHINE.**

## **SECTION IV**

### **MAINTENANCE**

#### **4-1 Before Each Use:**

- A. Check moisture trap and drain if needed
- B. Visually inspect machine for any unsafe condition
- C. Turn on compressed air supply
- D. Turn on electricity

#### **4-2 After Each Use:**

- A. Turn off blower fan
- B. Activate shaker valve on dust collector
- C. Turn off electricity
- D. Turn off compressed air supply
- E. Drain moisture trap

#### **4-3 Daily Inspection:**

- A. Clean trash screen in reclaimer
- B. Empty dust bag or dust collector

#### **4-4 Weekly Inspection:**

- A. Dust bags in dust collector
- B. Blast gun parts for wear
- C. Machine door gaskets
- D. Reclaimer door gasket
- E. Air hoses for leaks and loose clamps
- F. Media hose for holes or soft spots

#### **4-5 As Needed:**

- A. Add media
- B. Replace bags
- C. Replace worn gloves
- D. Replace window
- E. Replace reclaimer trash screen
- F. Replace any worn or defective blast gun parts
- G. Replace gaskets
- H. Replace hoses

# SECTION V

## BLAST GUN - SUCTION MACHINE

### 5-1 Operation - Ref. Dwg. M9009

The blast gun is the heart of the blasting operation. Worn parts or improper adjustment will reduce the effectiveness of the blasting process. Compressed air enters through the orifice (7) and is directed into the center of the nozzle (2). The amount of air passing through the orifice (7) is determined by its opening. The stream of compressed air enters the nozzle (2) venturi and creates a vacuum in the gun body (4). This vacuum draws media from the media metering valve (Ref. Dwg. M1115, M1211, Item 11) into the gun body (4) through the barbed fitting (10) at the bottom of the blast gun handle. The media is drawn into the nozzle (2) by the vacuum produced by the stream of compressed air and mixes with the compressed air. This mixture is then propelled from the nozzle onto the surface to be blasted. The air/media ratio is pre-set to give maximum blasting performance. To maintain a maximum blasting condition the blast gun must be properly adjusted with no worn parts.

### 5-2 Parts Replacement

- A. **Nozzle:** Remove nozzle nut (1) by turning counter-clockwise. Remove nozzle by pulling straight out from gun body (4). Remove old "O" ring (3). Insert new "O" ring (3) into gun body (4) until it rests squarely on the machine shoulder in the gun body (4). Insert new nozzle (2) into the gun body (4) with the tapered venturi end first, toward (7) orifice air. Make sure the nozzle (2) seats evenly on the "O" ring (3). Replace nozzle nut (1) and tighten by turning clockwise until hand tight.
- B. **Orifice:** Loosen clamp on ½ inch rubber hose attached to the barbed end of the orifice (7) and remove hose. Loosen orifice locknut (5) by turning counter clockwise until orifice (7) can be turned counter clockwise from the gun body (4). Inspect the end of the orifice (7), if brass is worn at an angle, replace orifice (7). The end of the orifice (7) must be straight or the stream of compressed air will not enter the nozzle (2) correctly, and vacuum will not be produced to draw media into the blast gun. The rubber cover (6) is placed on the orifice (7). The rubber cover (6) should be installed on the orifice (7) approximately 1/16 inch to 1/8 inch from end of the orifice (7). Insert orifice (7) into gun body (4) and turn clockwise approximately six turns. Replace 1/2" air hose to the barbed end of the orifice (7) and tighten clamp. Remove media hose from the bottom of the blast gun and connect 0-30 inches of water (H2O) vacuum gauge. Turn compressed air supply and electricity ON. Activate foot pedal and set air pressure to 80 PSI. With foot pedal activated, note reading on vacuum gauge. Adjust orifice (7) clockwise or counter clockwise until the maximum amount of vacuum is noted on the vacuum gauge. Release foot pedal and turn orifice locknut (5) clockwise until it holds orifice (7) securely in place.

# **SECTION VI**

## **RECLAIMER AIR WASH**

### **6-1 Operation**

#### **Reclaimer/Dust Bag:**

Media, dust and debris are removed from the blast cabinet and enters the reclaimer through the inlet. The air velocity created by the blower assembly causes the mixture removed from the cabinet to begin spinning in the reclaimer body. This spinning action separates the dust and small particles from the good media and debris. The dust is pulled from the reclaimer body through the inner tube assembly by the air velocity and discharges into the dust bag. Good media and debris falls to the trash screen, where the debris is trapped and re-usable media passes through to be used again. The amount of dust and small particles removed may be varied.

### **6-2 Operation**

#### **Reclaim Pull-Through**

The internal operation of a pull-through reclaimer is the same as described in 6-1; the only difference is that the motor assembly is located on the dust collector. An adapter is bolted onto the reclaimer in place of the blower assembly and a flex hose connects the reclaimer to the dust collector. The dust collector is equipped with an inlet damper which must also be adjusted (See 7-4, damper adjustment).

### **6-3 Air Wash Adjustment**

Placement of the slide tube for each type of blasting application cannot be a pre-determined setting. Many factors contribute to the air wash adjustment such as media type, media size, desired finish of part, etc. Adjustment of the slide tube must be made in small increments (approximately 1/4 inch.) in the direction needed to prevent over adjustment.

**Adjust slide tube up**, when good media is found in the material removed from the dust bag or dust collector. **Adjust the slide tube down** when excessive dust is found mixed with the media. To adjust the slide tube, move the switch to its OFF position and allow the motor to stop. Disengage reclaimer door latch and open the access door. Insert arm into reclaimer housing routing hand upward through the inner cone until the round slide tube is felt. Loosen the locking "T" handle located inside the slide tube, by turning counter-clockwise. Move the slide tube in the determined direction and lock in place by turning "T" handle clockwise. Carefully remove arm and close access door and latch to insure air tight seal. The machine should be operated under blast condition until the media has been circulated through the reclaim several times. Inspect media and dust again to determine if further adjustment is needed.

# **SECTION VII**

## **DUST COLLECTOR**

### **7-1 Operation**

The D10 (400-700 CFM) and D20 (900 CFM) Dust Collectors operate in the same manner; the area of dust collecting and the motor fan size is the only operation difference. The dust bags are equipped with one end closed while the other end remains open. The blower assembly, mounted on the side of the dust collector, creates an air flow through the dust bags. This air flow draws air, media, dust and debris from the blast cabinet into the reclaimer, where the dust is separated. The dust laden air from the reclaimer is drawn into the dust bags where the dust is trapped inside the bags. Clean air is then allowed to pass through the bags and exhausted from the blower assembly.

### **7-2 Cleaning**

The bag hanger is equipped with an air operated vibrator. This vibrator is activated by an air push button located on the side of the dust collector. Cleaning of the dust bags and emptying the dust from the sump is very critical for correct operation of the blast machine. Failure to clean the dust bags reduces air movement in the blast machine and reclaimer. Results of reduced air movement includes excessive dust in cabinet, improper reclaiming, etc. (See Trouble Shooting Guide).

Dust bags should be shaken after each use or more often if needed. To shake the dust bags, first move the switch to its OFF position and allow motor to stop rotating. Press the button on the shaker valve and hold for one minute. With motor off, place a container under the slide gate in the sump of the dust collector. Move slide gate to its open position and allow dust to flow into the container. Move slide gate to its closed position. **DISPOSE OF DUST IN AN APPROVED MANNER.** Do not cycle dust back into the system. Do not shake bags or open sump slide gate when motor is operating. Remove wing nuts and remove access door weekly and inspect dust bags. After extended use, the dust bags will become saturated with dust and will not pass sufficient air. At this time remove the dust bags and replace with new bags.

### **7-3 Bag Replacement**

Move the switch to its OFF position. De-energize electrical service switch and lock in its off position. Shake dust bags and empty sump as described in 7-2. Turn air supply to the unit off. Remove wing nuts and remove access door. Remove the closed end of the dust bag from the bag hanger at the top of the collector. Starting at the front, remove the bags from the bag holder. The open end of the bag has two coil springs sewn into the felt material. One spring is on each side of the bag holder. Pushing the springs inward will allow the bag to slip from its mounting hole.

**Caution:** Personnel protection should be taken against any dust that might escape during bag replacement. Some blasted items may produce dust that is harmful. Know what your dust contains.

To install new bags, begin by hanging the bags on the bag hanger using the loop sewn into the closed end of the bag. With the bags hanging in place, begin at the rear of the machine installing the open end of the dust bag into the bottom bag holder. Place one spring on each side of the bag holder metal. Working forward, install all bags carefully into their respective holder being careful not to cross any bags. Do not use any sharp object to install bags in bag holder. When all bags have been installed correctly, inspect and replace any worn gasket around the access door. Replace access door and tighten all wing nuts. When the blast machine is restarted, observe the exhaust from the blower for traces of dust. If dust is detected, remove access door and inspect bag installation and dust bags.

#### **7-4 Damper Adjustment**

Due to increased efficiency over the standard dust bag, the D10 and D20 dust collectors are equipped with an inlet damper. The inlet damper has an external adjustable handle which can be locked in place with a wingnut. The inlet damper should be open enough to maintain sufficient air flow for correct reclaiming and to clean dust from the cabinet. If inlet damper is open too far, it will tend to pull good media out of the reclaimer. Inspection of the dust removed from the dust collector will determine if the damper is open too far. A correct balance of the inlet damper of the dust collector and the air wash in the reclaimer will produce maximum use of selected media.

## **SECTION VIII**

### **Safety Blast Control**

#### **8-1 Operation**

##### **A. Air Operated**

A safety air valve is located above each cabinet door. This valve is activated when door(s) are closed.

**WARNING:** By-passing safety valve could cause a hazardous condition to personnel

# Section IX

## Trouble Shooting

### 9-A No Blast- No Air or Media

#### Probable Cause

1. Air supply to machine turned off.
2. Regulator adjusted too low.
3. Foot valve bad.
4. Nozzle or orifice plugged.
5. Air safety interlock.
6. Main regulator bad.
7. Control regulator bad.

#### **Solution**

- Turn on air supply
- Set regulator to 80 PSI
- Replace as needed
- Back blast gun. Check and/or replace
- Check & replace if needed
- Check & replace if needed.
- Check & replace if needed.

### 9-B No Media from Blast Gun (Air Only)

#### Probable Cause

1. Out of media
2. Media hose plugged.
3. Trash screen clogged.

#### **Solution**

- Add media to reclaimer sump
- Back blast
- Empty screen drawer Daily Maintenance

### 9-C Blast Nozzle Surging

#### Probable Cause

1. Media valve of hose plugged.
2. Contaminated media (WET OR OILY MEDIA)

#### **Solution**

- Clean or replace
- Remove and replace media

### 9-D Cabinet Cloudy

#### Probable Cause

1. Low air movement
2. Media too old / too fine.

#### **Solution**

- Check and empty dust filter(s)
- Make sure cabinet air inlets are not blocked
- Replace with new media

**9-E Low or No Air Movement**

**Probable Cause**

1. Fan motor not running.
2. Fan motor running in reverse
3. Incorrect fan speed.
4. Fan blade worn.
5. Dust bag full.
6. Dust collector full.
7. Air intake holes are blocked.
8. Inlet damper closed.
9. Flex hose - machine to reclaimer.

**Solution**

- Check motor/fan rotation.  
Reverse rotation. (See 3-2-S)  
Check for correct motor voltage  
Replace fan blade  
Empty dust bag.  
Shake bags and empty sump  
Remove any obstructions covering holes  
Adjust inlet damper. (See 7-4).  
Flex hose off - replace.

**9-F Reclaimer Not Separating  
(Dust in Media)**

**Probable Cause**

1. Contaminated media
2. Adjustable air wash in reclaimer set too high.
3. Low air movement.

**Solution**

- Replace media  
Re-set air wash  
Check as per 9-E.

**9-G Contamination of Media**

**Probable Cause**

1. Condensation in compressed air.
2. Oil in compressed air from air compressor.
3. Machine oil or cleaning solvents on parts
4. Atmospheric Humidity.

**Solution**

- Drain moisture trap more often.  
Install coalescing filter in compressor air supply.  
Parts being blasted should be cleaned in a solution that leaves no residue.  
Machine should be placed in a location where large amounts of outside humid air is not drawn through the system.

LARRY HESS & ASSOCIATES  
 DESCRIPTION STANDARD MACHINE REPLACEMENT PARTS  
 DATE 4/23/96  
 ENGINEER DEC  
 DWG. NO. M117

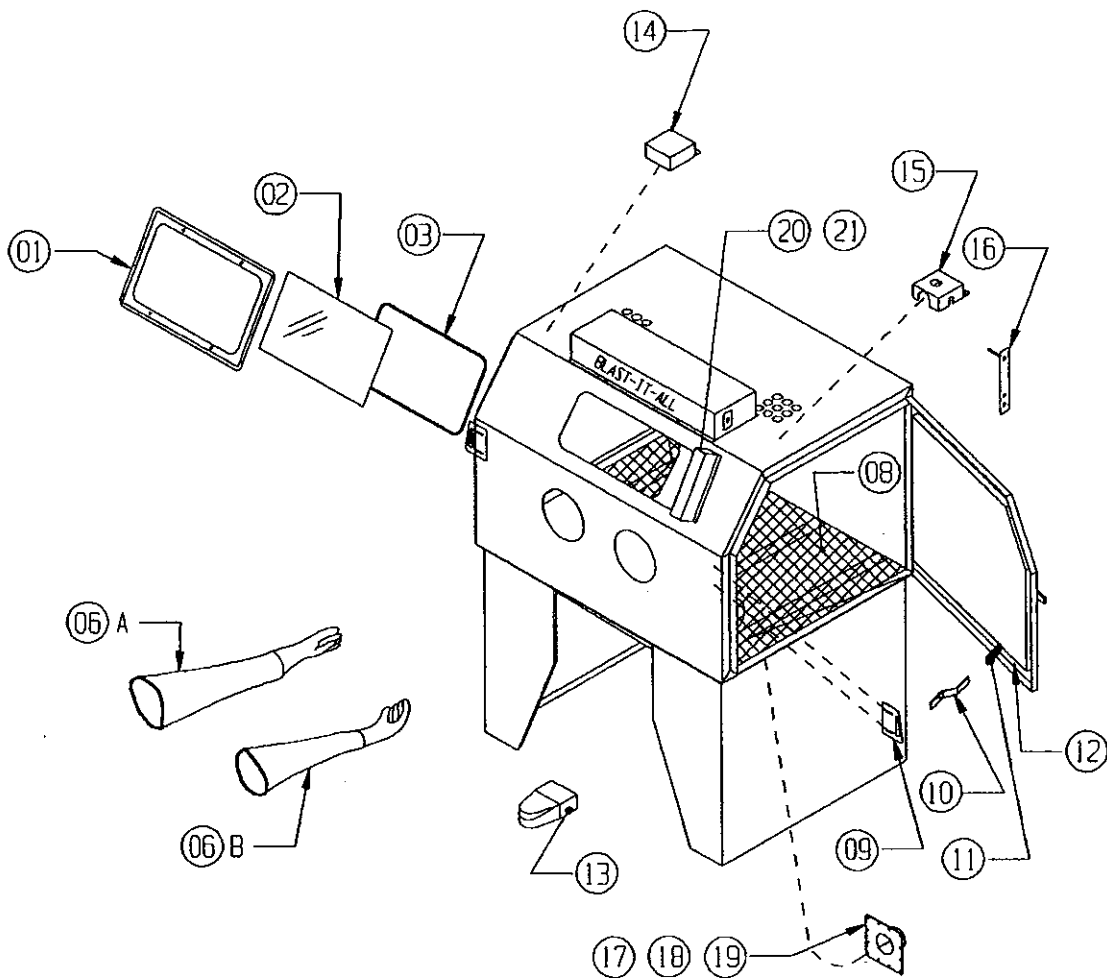

ITEM NO.	PART NO.	DESCRIPTION
1	23-053	WINDOW FRAME
2	23-050	WINDOW, VIEWING
3	24-059	WINDOW GASKET (SPECIFY LENGTH)
4	-----	-----
5	-----	-----
6	-----	-----
6A	22-111	GLOVE, SNAP-IN (LEFT ONLY)
6B	22-112	GLOVE, SNAP-IN (RIGHT ONLY)
7	-----	-----
8	-----	GRATE (REFER TO CHART →)
9	15-730	DOOR STRIKER (EITHER SIDE)
10	15-719	DOOR CAM (EITHER SIDE)
11	15-720	DOOR CAM RUBBER GRIP
12	24-025	DOOR GASKET (REFER TO CHART)
13	003190	FOOT VALVE
14	A117	SAFETY VALVE PANEL
15	A7170	CONTROL REGULATOR PANEL
16	A237	SAFETY DOOR CONTROL ARM
17	11-705	Ø 4" SLUMP OUTLET
18	11-905	Ø 5" SLUMP OUTLET
19	11-905-6	Ø 6" SLUMP OUTLET
20	011191	MYLAR GLASS PROTECTOR
21	011190	MYLAR HOLDER

MACHINE MODEL	GRATE PART NO.
3636	10-111
4426	10-112
4836	10-114
4848	10-115
6048	10-117
6060	10-118

MACHINE MODEL	DOOR GASKET NO.
3636	24-025 12'
4426	24-025 9'
4836	24-025 13'
4848	24-025 15'
6048	24-025 16'
6060	24-025 18'

GASKET PER DOOR

LARRY HESS & ASSOCIATES

DESCRIPTION

BIA LIGHT BOX

DATE 4/23/96

ENGINEER

DEC

DWG. NO.

M129

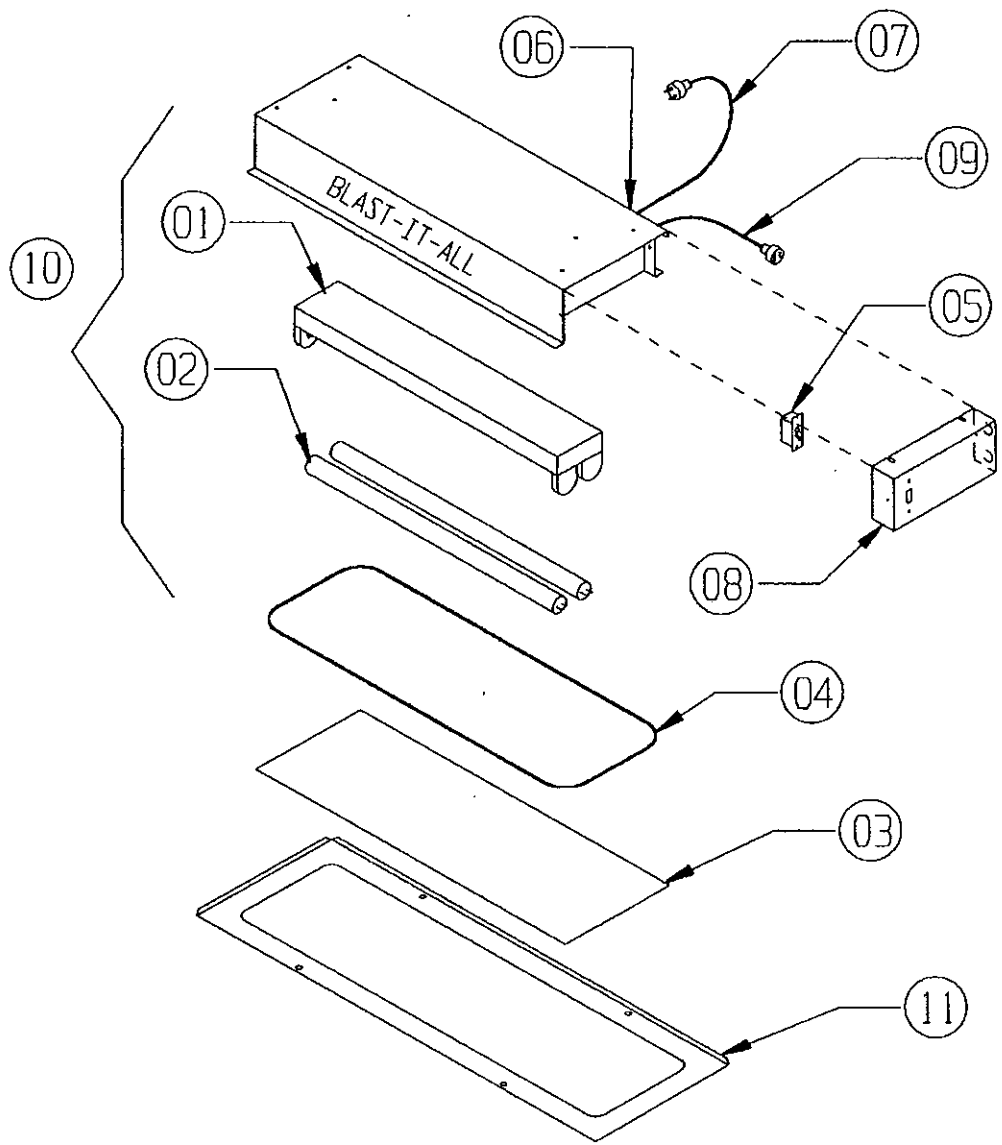

ITEM NO.	PART NO.	DESCRIPTION
1	13-533	FLUORESCENT FIXTURE, (NO TUBES)
2	13-534	24" FLUORESCENT TUBE
3	23-058	PROTECTOR, LIGHT
4	23-059	GASKET
5	13-655	SWITCH
6	13-605	ROUND CONNECTOR
7	13-550	POWER CORD, 3 WIRE
8	B198-2	SWITCH MOUNTING PLATE
9	010172F	CORD WITH FEMALE PLUG
10	010801	COMPLETE LIGHT BOX (EXCEPT 3 & 4 & 11)
11	A506	LIGHT BOX WINDOW FRAME

DWG. NO. A7232

ENGINEER DEC

DATE 08/07/09

STANDARD AIR CONTROL

DESCRIPTION

LARRY HESS & ASSOCIATES

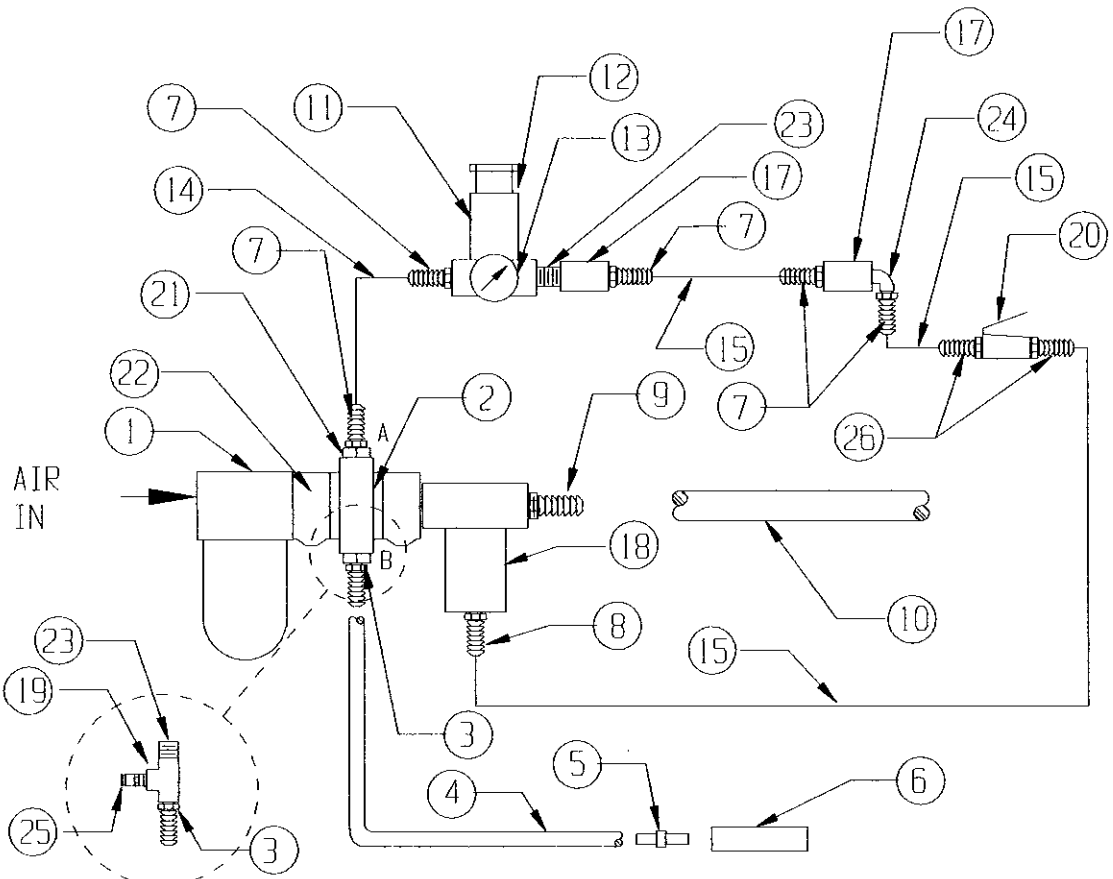

ITEM NO.	PART NO.	QTY.	DESCRIPTION
1	16-966	1	FILTER
2	012119	1	"T" BLOCK
3	14-316	1	FITTING 1/4" x 1/8"
4	18-074	*	HOSE, 1/4"
5	14-313	1	FITTING 1/4" x 1/4"
6	16-822	1	NOZZLE BLOW-OFF
7	006270	5	FITTING 1/8" x 1/8"
8	010599	1	FITTING 1/8" x 1/4"
9	14-301	1	FITTING 1/2" x 1/2"
10	18-076	*	HOSE, AIR 1/2"
11	001564	1	REGULATOR, 1/8"
12	001564-N	1	NUT FOR REGULATOR
13	16-820	1	GAUGE, 1/8" BACK
14	010601	*	TUBING, RED
15	010602	*	TUBING, BLUE
16	-----	-	-----
17	010600	2	VALVE, AIR 1/8" 3-WAY (SAFETY DOOR)
18	010598	1	REGULATOR, 1/2"
19	14-326	1	TEE, 1/8" (OPTIONAL WITH DUST COLLECTOR)
20	003190	1	VALVE, FLOATING (FOOT CONTROL)
21	010171	2	BUSHING, 1/2 x 1/8
22	012117	2	BODY CONNECTOR
23	002405	1	1/8" CLOSE NIPPLE
24	001129	1	1/8" STREET ELL
25	16-951	1	FITTING, 1/4 TUBE x 1/8 NPT
26	003083	2	90° SWIVEL, 1/4 x 1/4

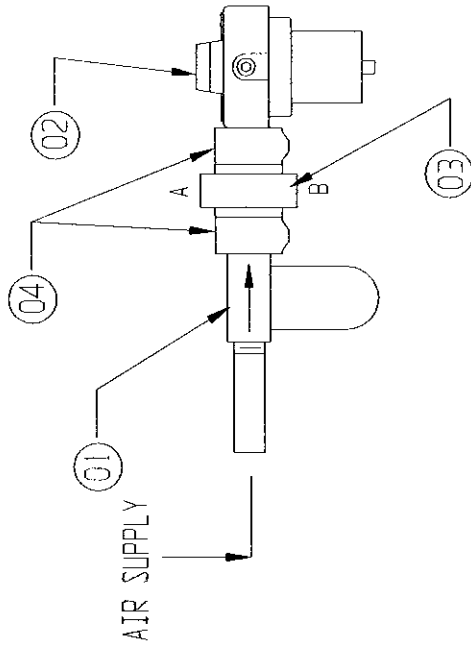

\*\*\*COMPLETE ASSEMBLY - 012121

04	2	BODY CONNECTOR	012117
03	1	"T" BLOCK	012119
02	1	REGULATOR, 1/2"	010598
01	1	FILTER, 1/2"	16-966
ITEM NO.	QTY.	DESCRIPTION	DWG NO. / MATERIAL
<b>LARRY HESS &amp; ASSOCIATES, INC.</b> SALISBURY, NORTH CAROLINA			
DESCRIPTION:		AIR CONTROL ASSEMBLY	MATERIAL: PER DWG.
		SUCTION	
DATE	SCALE	JOB NO.	DRAWING NO.:
06/22/09	NONE		A7230
DATE	BY	DATE	

**CONFIDENTIAL**

THE DISCLOSURES AND CONTENTS OF THIS DRAWING ARE CONFIDENTIAL AND ARE THE EXCLUSIVE PROPERTY OF BLAST-IT-ALL® A DIV. OF LARRY HESS & ASSOCIATES, INC. THIS DRAWING IS NOT TO BE COPIED OR REPRODUCED WHOLLY OR IN PART WITHOUT WRITTEN PERMISSION OF LARRY HESS & ASSOCIATES, INC.

REV.	DESCRIPTION	BY	DATE

LARRY HESS & ASSOCIATES  
 STANDARD BLAST GUN  
 DATE 4/23/96  
 ENGINEER DEC  
 DWG. NO. M9009

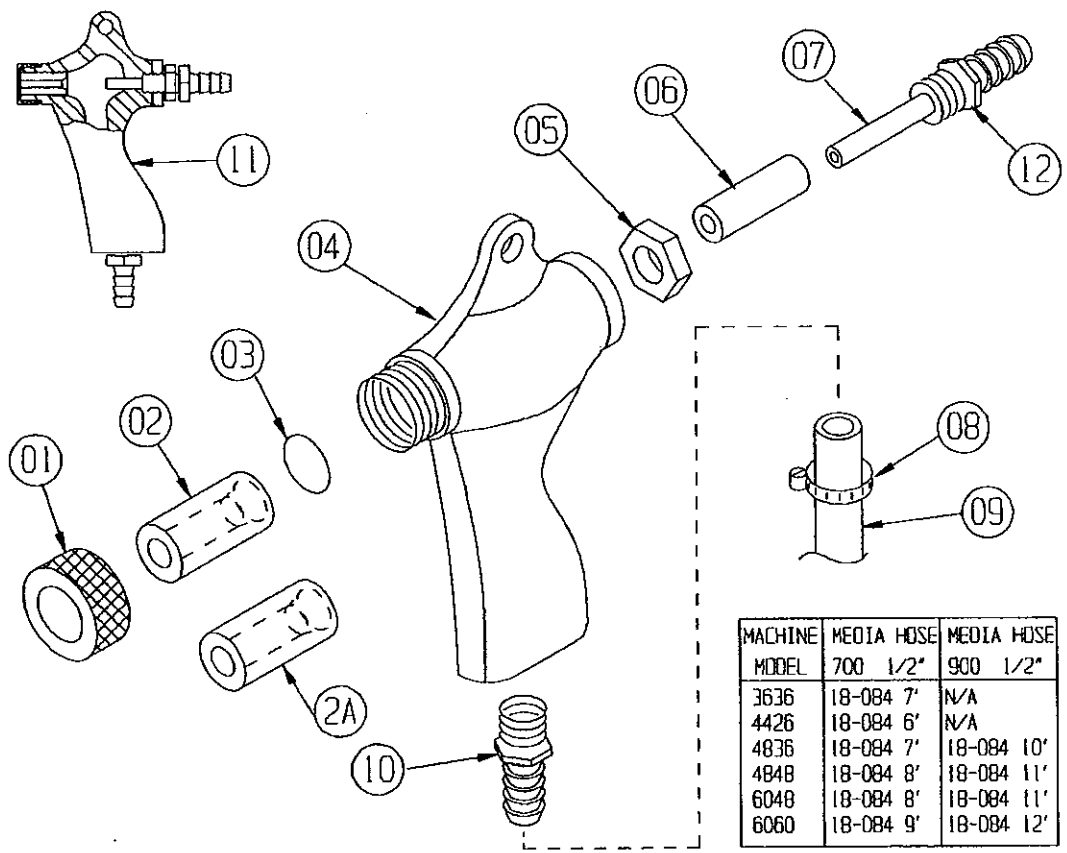

ITEM NO.	PART NO.	DESCRIPTION
1	20-054	NOZZLE NUT HOLDING
2	20-074	NOZZLE CERAMIC, 1/4" I.D. SIZE 4
2	20-075	NOZZLE CERAMIC, 5/16" I.D. SIZE 5
2	20-076	NOZZLE CERAMIC, 3/8" I.D. SIZE 6
2	20-077	NOZZLE CERAMIC, 7/16" I.D. SIZE 7
2	20-078	NOZZLE CERAMIC, 1/2" I.D. SIZE 8
2A	20-084	NOZZLE CARBIDE, 1/4" I.D. SIZE 4
2A	20-085	NOZZLE CARBIDE, 5/16" I.D. SIZE 5
2A	20-086	NOZZLE CARBIDE, 3/8" I.D. SIZE 6
2A	20-087	NOZZLE CARBIDE, 7/16" I.D. SIZE 7
2A	20-088	NOZZLE CARBIDE, 1/2" I.D. SIZE 8
3	20-053	"O" RING - NOZZLE SEALING
4	20-040	GUN BODY ONLY
5	20-052	LOCKNUT, ORIFICE
6	20-063	RUBBER COVER, ORIFICE
7	20-064	ORIFICE AIR 4/32" I.D. SIZE 4 INCL. #6 & 7
7	20-065	ORIFICE AIR 5/32" I.D. SIZE 5 INCL. #6 & 7
7	20-066	ORIFICE AIR 6/32" I.D. SIZE 6 INCL. #6 & 7
7	20-067	ORIFICE AIR 7/32" I.D. SIZE 7 INCL. #6 & 7
7	20-068	ORIFICE AIR 8/32" I.D. SIZE 8 INCL. #6 & 7
8	21-032	CLAMP, HOSE
9	18-084	HOSE, MEDIA 1/2" I.D. (SEE CHART)
10	14-304	FITTING-HOSE TO GUN 1/2" HOSE x 3/8" MPT
11	20-041	GUN, STD. COMP. W/CERAMIC NOZZLE (SPECIFY SIZE)
11	20-042	GUN, STD. COMP. W/CARBIDE NOZZLE (SPECIFY SIZE)
12	-----	GUN SIZE IS STAMPED ON AIR ORIFICE HEX SIDE

M1005

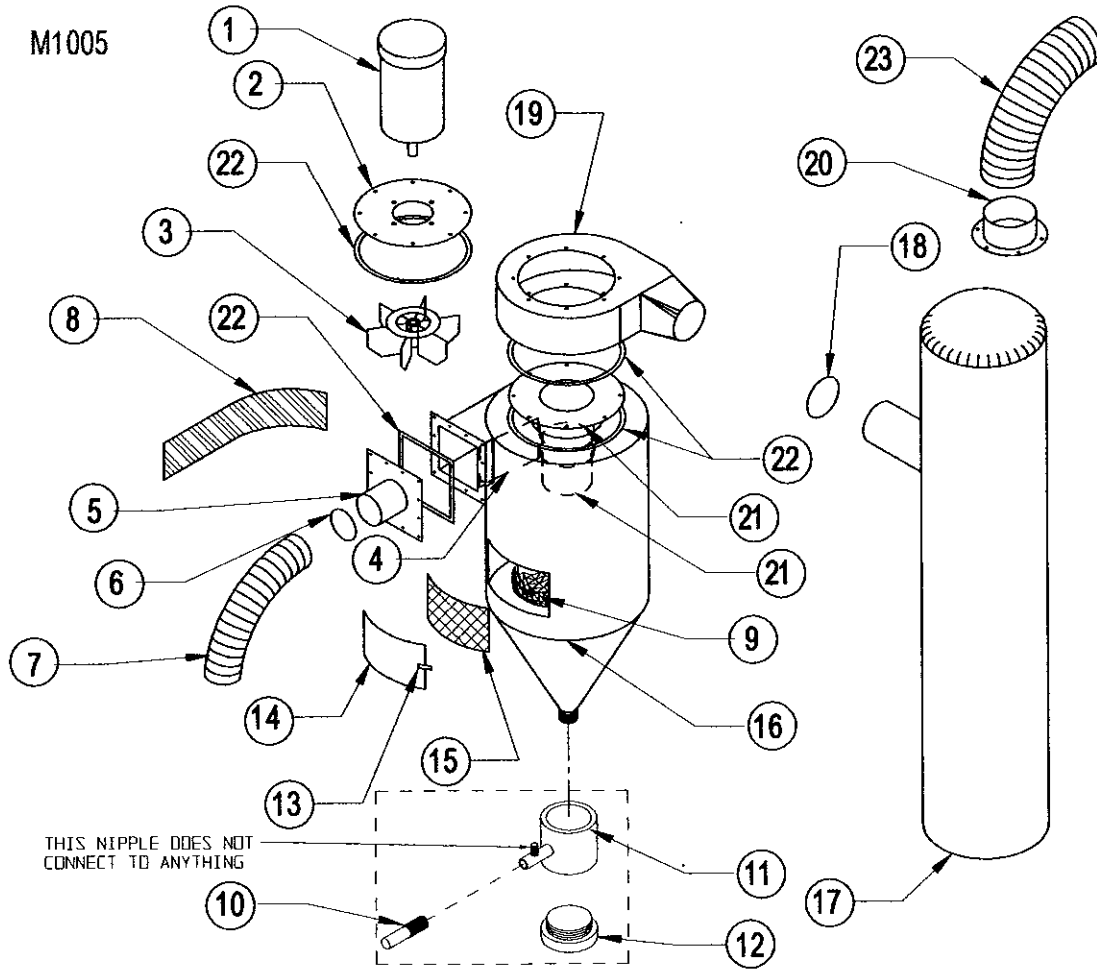

THIS NIPPLE DOES NOT  
CONNECT TO ANYTHING

ITEM NO.	400 CFM	DESCRIPTION
1	13-400	MOTOR, 1/2 HP, 1PH
2	11-420	MOTOR PLATE
3	11-418	BLADE
4	11-428	BAFFLE
5	11-405	INLET ADAPTOR 4"
6	21-034	CLAMP
7	*	FLEX HOSE 4" (SEE CHART)
8	11-417	INLET WEAR PLATE (OPTIONAL)
9	11-406	STD. SCREEN BASKET
9	11-429	BASKET, HEAVY DUTY (OPTIONAL)
10	14-301	FITTING, 1/2" x 1/2"
11	20-200	MEDIA VALVE, 2"
12	20-201	DRAIN PLUG
13	15-728	DOOR LATCH & CATCH ASMB.
14	11-402	DOOR AND GASKET
15	11-403	GASKET (ONLY)
16	11-401	RECLAIMER HOUSING
17	11-415	DUST BAG
18	21-036	CLAMP
19	11-416	BLOWER HOUSING
20	002028	TOP OUTLET (USED WITH DUST COLLECTOR) 6"
21	11-431	INNER VACUUM TUBE WITH SLIDE TUBE
22	24-030-3	PUTTY TAPE
23	19-096-6	FLEX HOSE, 6" TO DUST COLLECTOR (USE WITH #20) 6' LONG

MACHINE	FLEX SLIMP
MODEL	TO REC.
3636	19-096 6'
4426	19-096 6'

LARRY HESS & ASSOCIATES  
 DESCRIPTION STANDARD 700 CFM RECLAIMER  
 DATE 6/05/96  
 ENGINEER DEC  
 Dwg. No. M1115

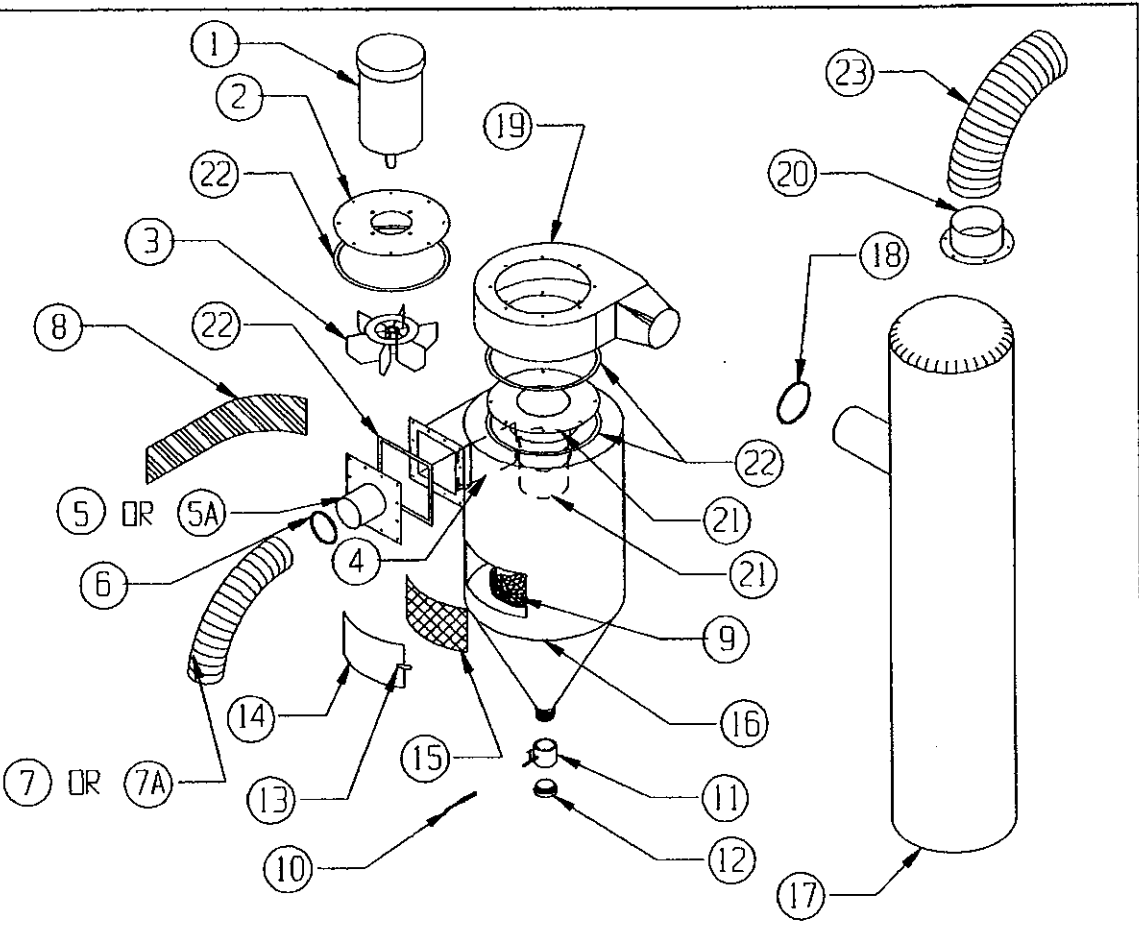

ITEM NO.	700 CFM	DESCRIPTION
1	13-700	MOTOR, 1 HP, 1 PH
2	11-720	MOTOR PLATE
3	11-718	BLADE
4	11-728	BAFFLE
5	11-705	INLET ADAPTOR 4"
5A		5" Ø INLET ADAPTOR 11-905
6	21-034	CLAMP
7	*	FLEX HOSE 4" (SEE CHART) (7A) FLEX HOSE 5" (SEE CHART)
8	11-717	INLET WEAR PLATE (OPTIONAL)
9	11-706	STD. SCREEN BASKET
9	11-729	BASKET, HEAVY DUTY
10	14-301	FITTING, 1/2" x 1/2"
11	20-200	MEDIA VALVE, 2"
12	20-201	DRAIN PLUG
13	15-728	DOOR LATCH & CATCH ASMB.
14	11-702	DOOR AND GASKET
15	11-703	GASKET (ONLY)
16	11-701	RECLAIMER HOUSING
17	11-715	DUST BAG
18	21-036	CLAMP
19	11-716	BLOWER HOUSING
20	002028	TOP OUTLET 6" (USED WITH DUST COLLECTOR)
21	11-731	INNER VACUUM TUBE WITH SLIDE TUBE
22	24-030	PUTTY TAPE
23	19-096-6	FLEX HOSE, 6" TO DUST COLLECTOR (USE WITH #20) 6' LONG

MACHINE MODEL	FLEX SLUMP TO REC. 4'	FLEX SLUMP TO REC. 5'
3636	19-092 7'	19-094 7'
4426	19-092 6'	19-094 6'
4836	19-092 7'	19-094 7'
4848	19-092 7'	19-094 7'
6048	19-092 7'	19-094 7'
6060	N/A	N/A

LARRY HESS & ASSOCIATES  
 DESCRIPTION STANDARD 900 CFM RECLAIMER  
 DATE 6/07/96  
 ENGINEER DEC  
 DWG. NO. M1211

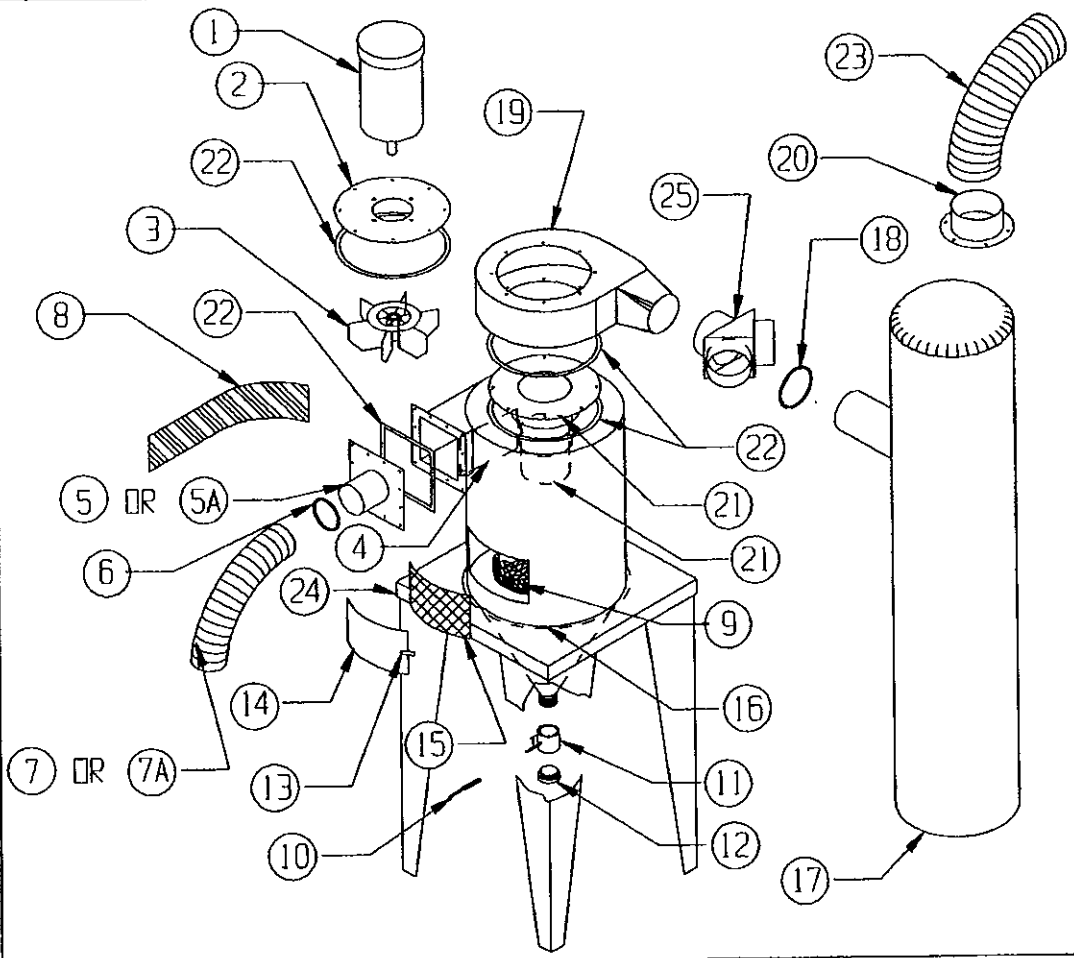

ITEM NO.	900 CFM	DESCRIPTION
1	13-900	MOTOR, 2 HP, 3 PH
2	11-920	MOTOR PLATE
3	11-918	BLADE
4	11-928	BAFFLE
5	11-905	INLET ADAPTOR 5" (5A) 6"Ø INLET ADAPTOR A12767
6	21-035	CLAMP
7	*	FLEX HOSE 5" (SEE CHART) (7A) FLEX HOSE 6" (SEE CHART)
8	11-917	INLET WEAR PLATE (OPTIONAL)
9	11-906	STD. SCREEN BASKET
9	11-929	BASKET, HEAVY DUTY
10	14-301	FITTING, 1/2" x 1/2"
11	20-200	MEDIA VALVE, 2"
12	20-201	DRAIN PLUG
13	15-728	DOOR LATCH & CATCH ASMB.
14	11-902	DOOR AND GASKET
15	11-903	GASKET (ONLY)
16	11-910	RECLAIMER HOUSING
17	11-915	DUST BAG (QTY. 2)
18	21-036	CLAMP
19	11-916	BLOWER HOUSING
20	003153	TOP OUTLET 8" (USED WITH DUST COLLECTOR)
21	11-931	INNER VACUUM TUBE WITH SLIDE TUBE
22	24-030-3	PUTTY TAPE
23	19-098-6	FLEX HOSE, 8" TO DUST COLLECTOR (USE WITH #20) 6' LONG
24	007471	STAND
25	11-912	OUTLET "Y" (WYE)

MACHINE MODEL	FLEX SUMP TO REC. 5"	FLEX SUMP TO REC. 6"
3636	N/A	N/A
4426	N/A	N/A
4836	19-094 8'	19-096 8'
4848	19-094 8'	19-096 8'
6048	19-094 8'	19-096 8'
6060	19-094 10'	19-096 10'

B2129-4

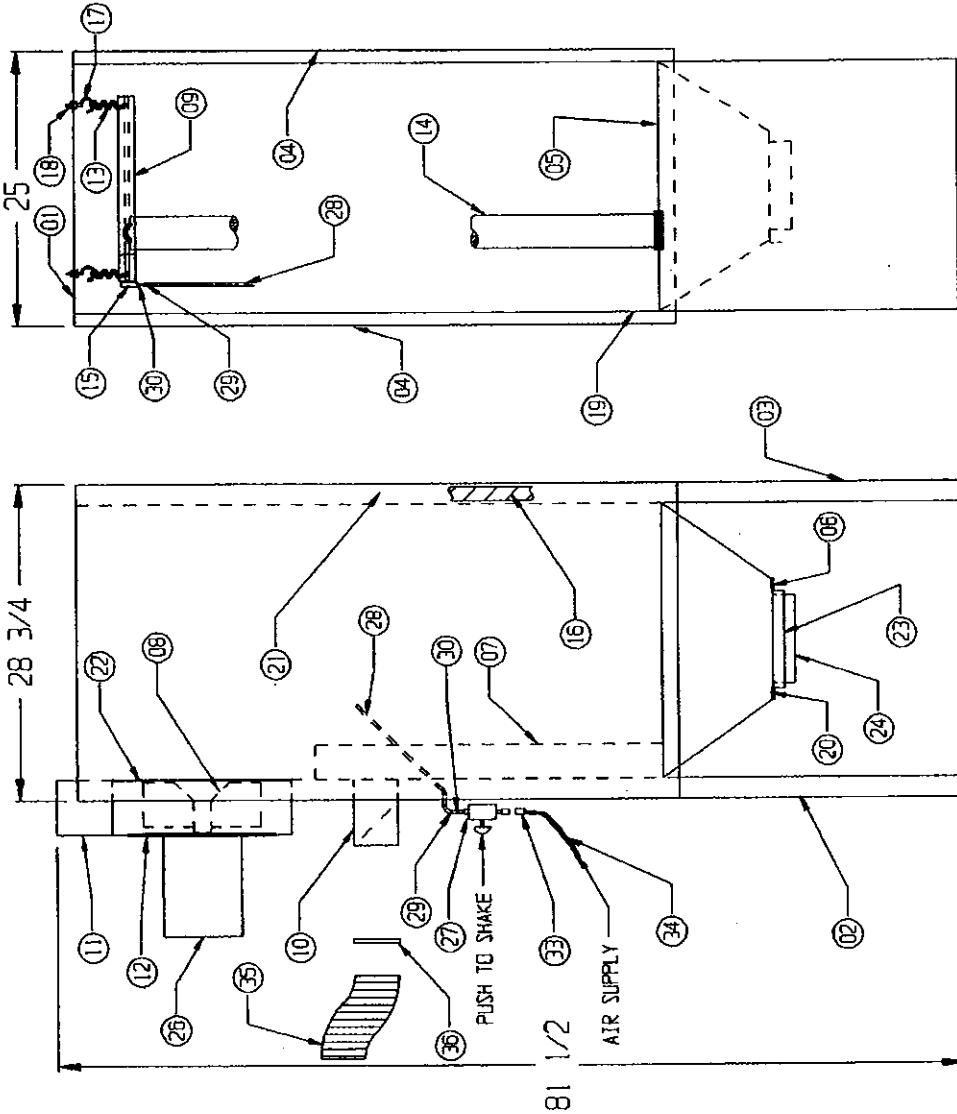

ITEM NO.	QTY.	DESCRIPTION	ONG. NO. / MATERIAL
38			
37			
36	2	SCREEN CLAMP	21-085
35	5'	FLEX HOSE (5')	19-094-5
34	6'	1/4" PLASTIC HOSE	18-111
33	1	1/4" x 1/4" MPT MALE CONNECTOR	18-951
32			
31			
30	2	1/8" x 1/4" HOSE BARB	14-316
29	2	1/4" SCREEN CLAMPS	21-080
28	3'	1/4" AIR HOSE	19-074
27	1	SHAKER VALVE 1/8"	18-680
26	1	MOTOR 1/2 HP-120V 56C	13-400
25			
24	1	OUTLET FLANGE 8" DIA.	000725
23	1	SLIDE GATE	000324
22	1	400 ADAPTOR PLATE	A1042
21	12	1/4" WING NUT	30-510
20	80	1/4" x 3/4" L.G. ROLLER	30-147
19	12	1/4" x 1" L.G. ROLLER	30-148
18	8	3/16" HEX NUT	30-500
17	4	3/16" EYE BOLT	000379
16	50'	1/2" x 1" GASKET	24-054
15	1	SHAKER	16-919
14	25	DUST BAG	11-349
13	4	SPRING	15-721
12	1	BLOWER/MOTOR PLATE	11-420
11	1	BLOWER HOUSING ASS'Y.	11-416
10	1	INLET DAMPER ASS'Y. (5" DIA.)	19-303
09	1	DUST BAG MOUNT ASS'Y.	A2501
08	1	BLADE ASS'Y.	11-418
07	1	D-10 PLENUM ASS'Y.	000355
06	1	SPACER	000330
05	1	SUPP ASS'Y.	A2500
04	2	DOOR PANEL	A2486
03	1	RIGHT SIDE PANEL	A2485-1
02	1	LEFT SIDE PANEL	A2484-1
01	1	TOP PLATE	A2487-1
ITEM NO.	QTY.	DESCRIPTION	ONG. NO. / MATERIAL

LARRY HESS & ASSOCIATES, INC.  
 SALISBURY, NORTH CAROLINA

DESCRIPTION: (400 CFM)  
 D-10 DUST COLLECTOR ASS'Y. PER DWG.

DATE: 3/28/11  
 DRAWING NO.: B2129-4

**CONFIDENTIAL**

THE DESIGNER AND CONTENTS OF THIS DRAWING ARE CONFIDENTIAL AND ARE THE PROPERTY OF LARRY HESS & ASSOCIATES, INC. THIS DRAWING IS NOT TO BE COPIED OR REPRODUCED WHOLLY OR IN PART WITHOUT WRITTEN PERMISSION OF LARRY HESS & ASSOCIATES, INC.

REV.	DESCRIPTION	BY	DATE

B2129

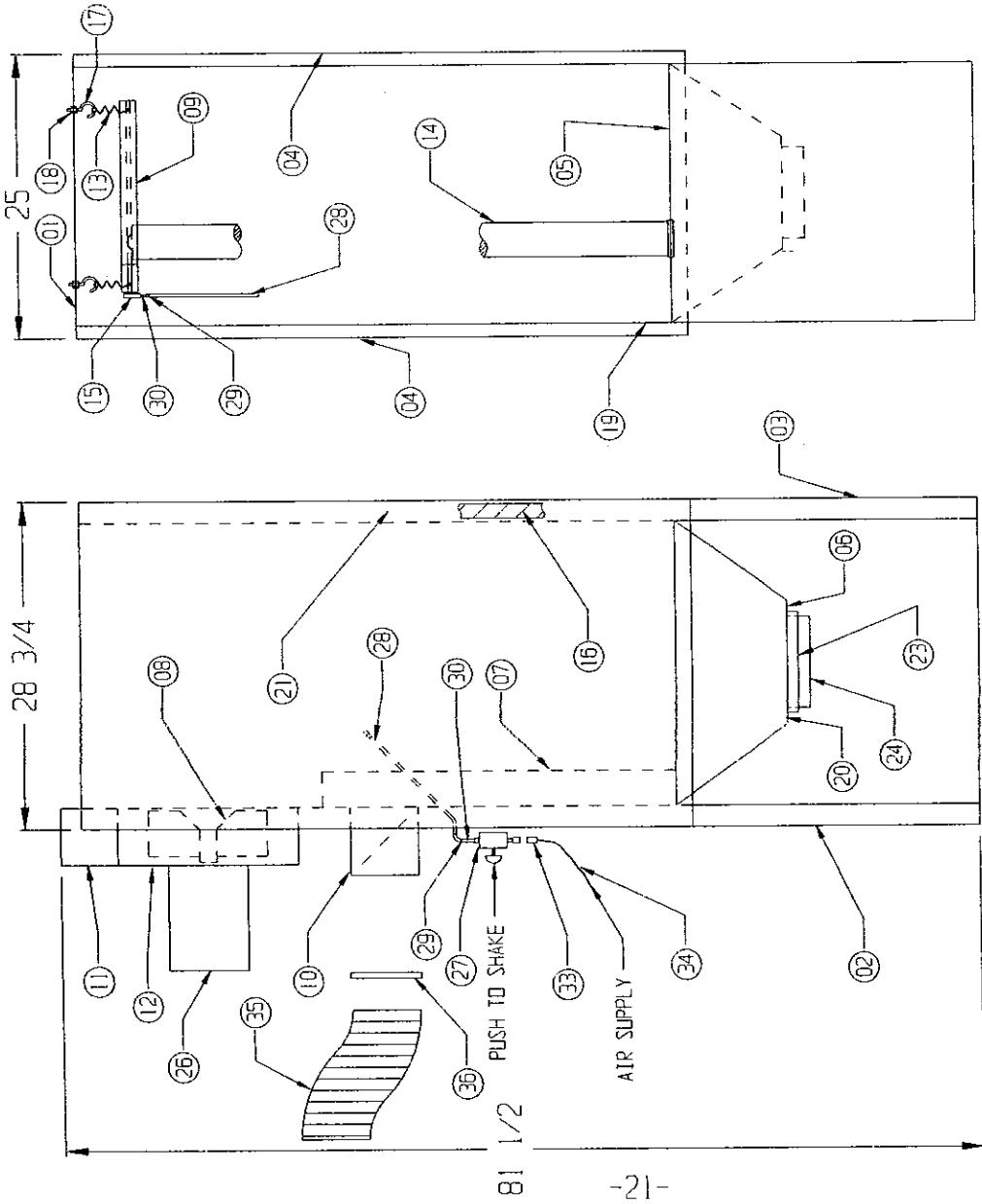

ITEM NO.	QTY.	DESCRIPTION	DWG. NO. / MATERIAL
38			
37			
36	2	SCREW CLAMP	21-036
35	5	FLEX HOSE (6")	19-096
34	6	1/4" PLASTIC HOSE	18-111
33	1	MALE CONNECTOR	16-951
32			
31			
30	2	1/8" x 1/4" HOSE BARB	14-316
29	2	1/4" SCREW CLAMPS	000496
28	3	1/4" AIR HOSE	18-074
27	1	SHAKER VALVE 1/8"	16-830
26	1	MOTOR 1HP-110V 56C	13-700
25			
24	1	OUTLET FLANGE 8" DIA.	000725
23	1	SLIDE GATE	010324
22			
21	6	1/4" WING NUT	000305
20	60	1/4" x 3/4 LG. ROLLID	000301
19	12	1/4" x 1" LG. ROLLID	000377
18	8	3/16" HEX NUT	000378
17	4	3/16" EYE BOLT	000379
16	50'	1/2" x 1" GASKET	24-054
15	1	SHAKER	16-919
14	25	DUST BAG	11-349
13	4	SPRING	15-721
12	1	BLOWER/MOTOR PLATE	11-720
11	1	BLOWER HOUSING ASS'Y.	11-716
10	1	INLET DAMPER ASS'Y. (6" DIA.)	000723
09	1	DUST BAG MOUNT ASS'Y.	A2501
08	1	BLADE ASS'Y.	11-718
07	1	D-10 PLENUM ASS'Y.	000335
06	1	SPACER	000329
05	1	SUMP ASS'Y.	A2500
04	2	DOOR PANEL	A2486
03	1	RIGHT SIDE PANEL	A2485-1
02	1	LEFT SIDE PANEL	A2484-1
01	1	TOP PLATE	A2487-1

LARRY HESS & ASSOCIATES, INC.  
SALISBURY, NORTH CAROLINA

DESCRIPTION: 700 CFM  
D-10 DUST COLLECTOR ASS'Y.  
MATERIAL: PER DWG.  
DRAWING NO.: B2129

B2131

38						
37						
36	2	SCREEN CLAMP (8")				21-036 DR 000310
35	8'	FLEX HOSE (8')				19-098
34	6'	1/4" PLASTIC HOSE				18-111
33	1	MALE CONNECTOR				16-951
32						
31						
30	2	1/8" x 1/4" HOSE BARB				14-316
29	2	1/4" SCREEN CLAMPS				000496
28	3'	1/4" AIR HOSE				18-074
27	1	SHAKER VALVE 1/8"				16-830
26	1	MOTOR 2HP-220/440V 3PH				13-900
25						
24	1	OUTLET FLANGE 8" DIA.				000725
23	1	SLIDE GATE				000324
22						
21	6	1/4" WING NUT				000305
20	80	1/4" x 3/4" LG. ROLLER				000301
19	12	1/4" x 1" LG. ROLLER				000377
18	12	3/16" HEX NUT				000378
17	6	3/16" EYE BOLT				000379
16	50'	1/2" x 1" GASKET				24-054
15	1	SHAKER				16-919
14	49	DUST BAG				11-349
13	6	SPRING				000347
12	1	BLOWER/MOTOR PLATE				11-920
11	1	BLOWER HOUSING ASS'Y.				11-916
10	1	INLET DAMPER ASS'Y. (8" DIA.)				001046
09	1	DUST BAG MOUNT ASS'Y.				A2507
08	1	BLADE ASS'Y.				11-918
07	1	D-20 PLENUM ASS'Y.				001051
06	1	SPACER				000329
05	1	SUMP ASS'Y.				A2506
04	2	DOOR PANEL				A2492
03	1	RIGHT SIDE PANEL				A2495
02	1	LEFT SIDE PANEL				A2496
01	1	TOP PLATE				A2494

ITEM NO. QTY. DESCRIPTION DWG. NO. / MATERIAL

DESCRIPTION: D-20 DUST COLLECTOR ASS'Y. PER DWG.  
 MATERIAL: LARRY HESS & ASSOCIATES, INC. SALISBURY, NORTH CAROLINA  
 DRAWING NO.: B2131

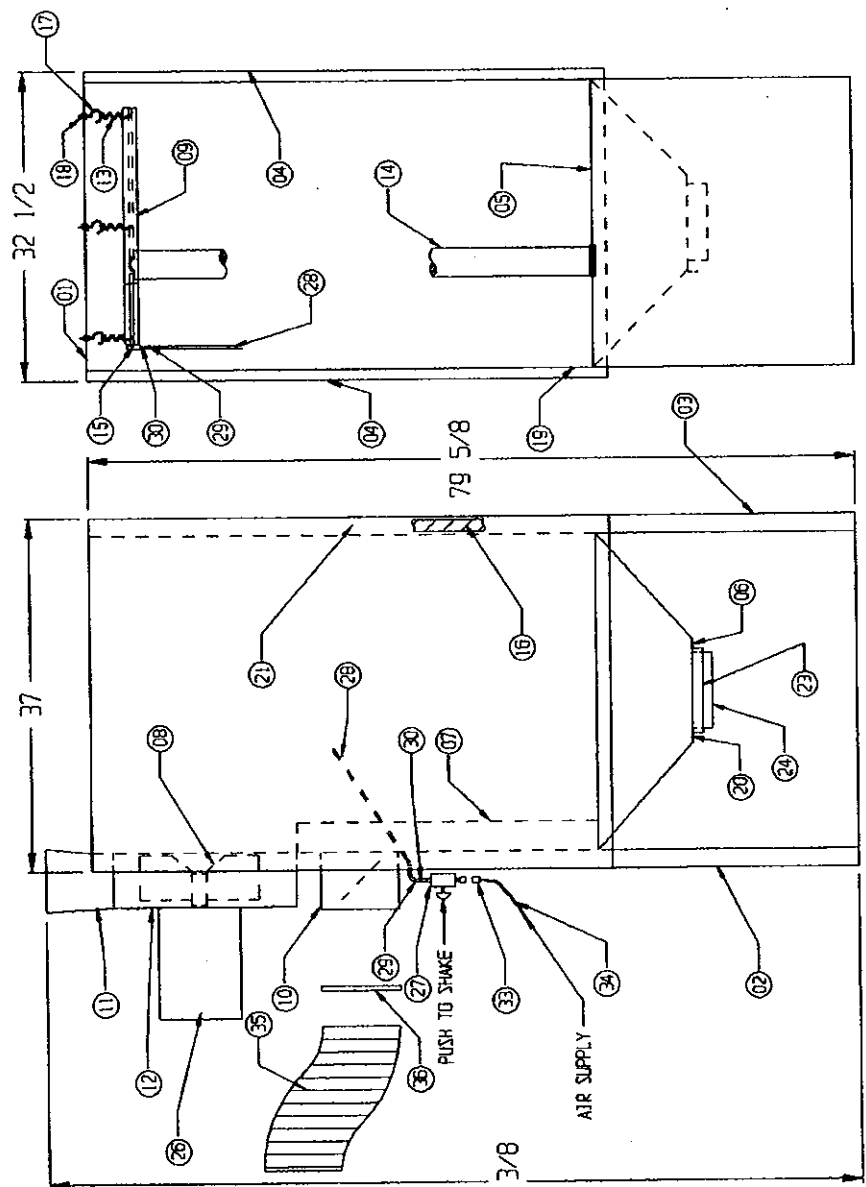

84 3/8

**CONFIDENTIAL**  
 THE DIMENSIONS AND CONTENTS OF THIS DRAWING ARE CONFIDENTIAL AND ARE THE SOLE PROPERTY OF LARRY HESS & ASSOCIATES, INC. THIS DRAWING IS NOT TO BE COPIED OR REPRODUCED WHOLLY OR IN PART WITHOUT WRITTEN PERMISSION OF LARRY HESS & ASSOCIATES, INC.

REV.	DESCRIPTION	BY	DATE

LARRY HESS & ASSOCIATES  
 DESCRIPTION 208-230/460 3 PHASE ELECTRICAL SCHEMATIC  
 DATE 4/23/96  
 ENGINEER DEC  
 DWG. NO. B5102-M

REV. 03/02/05 BY DEC

208 / 230 / 460 VOLTS  
3 PHASE

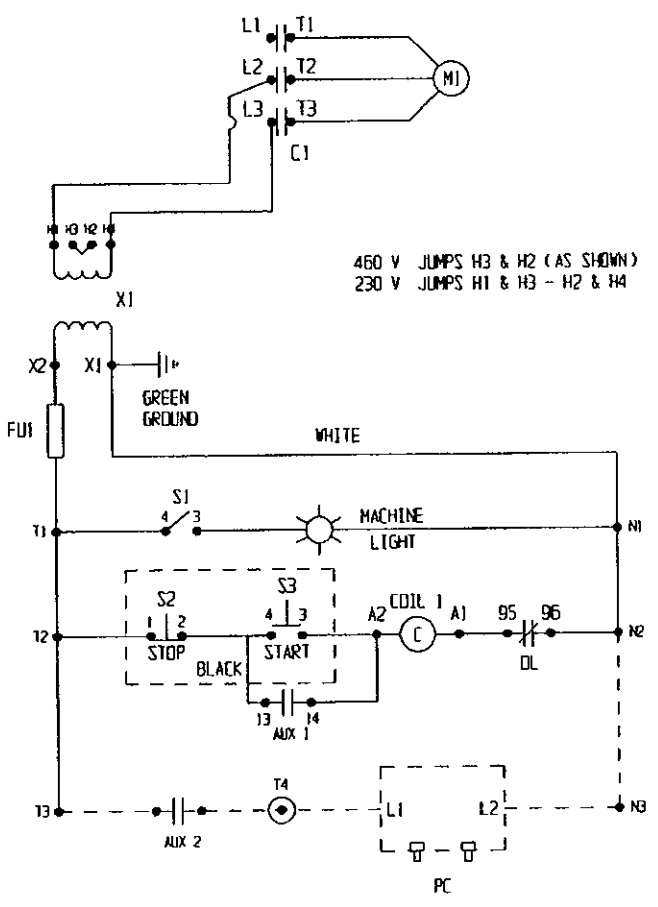

SWITCH NO.	FUNCTION	PART NO.
S1	MACHINE LIGHT - OFF/ ON	13-655
S2	M1 (PUSH TO STOP)	
S3	M1 (PUSH TO START) STARTS M1	
X1	TRANSFORMER (250 VA 2 LIGHTS)	000117
X1	TRANSFORMER (150 VA 1 LIGHT)	010222
FU1	FUSE	13-101-5A
FH	FUSE HOLDER	13-101
C1	CONTACTOR	010210-S
OL	OVERLOAD (230 V) 2 HP	010223-S
OL	OVERLOAD (460 V) 2 HP	010211-S
M1	MOTOR (2 HP) 3 PH	13-900
OL	OVERLOAD (230 V) 1HP	010211-S
OL	OVERLOAD (460 V) 1 HP	011795
M1	MOTOR (1 HP) 3 PH	13-701
PC	PULSE CONTROL BOARD (RPJ ONLY)	010453
AUX 1	AUXILLARY CONTACT (2 NO)	011720

## WARRANTY

Larry Hess & Associates, Inc. Warrants to the original purchaser the merchandise sold to be free from defects in material and workmanship under normal use and service for a period of one (1) year. Upon prompt notification by the buyer, to LHA, components that are determined by LHA to be defective will be repaired or replaced at no additional charge, F.O.B. our factory.

Manufacturer shall have the right to inspect prior to replacing all merchandise in question.

This warranty does not apply to parts that are directly involved in the blasting operation. Example: gun, gun parts, viewing window, hose, gloves, etc.

Manufacturer shall not be required to pay any removal or installation charges whatsoever under this warranty.

Manufacturer shall not be liable for prospective profits, special or consequential damages, nor shall any recovery of any kind against manufacturer be greater in amount than the cost of repairs of defects in workmanship.

This warranty does not apply to damage caused by accidents, damage in transit, alterations by unauthorized personnel, abuse or damage by flood, fire, or acts of God, nor by artificially generated electric currents or any other cause whatsoever except defects in material or factory workmanship.

In all cases, defective parts must be returned to Larry Hess & Associates, Inc. before credit is issued.

If genuine BLAST-IT-ALL® replacement parts are not used, the warranty is void.

This warranty is in lieu of all other warranties expressed or implied and releases Larry Hess & Associates, Inc. of all other obligations and liabilities whatsoever. This warranty neither assumes nor authorizes any person to assume any obligation other than those specified by this warranty.

## WARNING

**DO NOT USE SAND. SAND WILL CAUSE SILICA DUST, WHICH IS THE CAUSE OF SILICOSIS DISEASE, A CONDITION OF MASSIVE FIBROSIS OF THE LUNGS. THIS STATEMENT INDICATES POTENTIAL PERSONNEL HAZARD. FAILURE TO COMPLY WITH THESE INSTRUCTIONS MAY RESULT IN PERSONAL INJURY.**

**BLAST-IT-ALL®**

Larry Hess & Associates, Inc.

Airport Industrial Park

185 Piper Lane

P.O. Box 1615

Salisbury, NC 28145-1615