

# BLAST-IT-ALL®

## REVERSE PULSE DUST COLLECTOR

**WARNING**

DO NOT USE *SAND*. SAND WILL CAUSE SILICA DUST, WHICH IS THE CAUSE OF SILICOSIS DISEASE, A CONDITION OF MASSIVE FIBROSIS OF THE LUNGS. *THIS STATEMENT INDICATES POTENTIAL PERSONNEL HAZARD. FAILURE TO COMPLY WITH THESE INSTRUCTIONS MAY RESULT IN PERSONAL INJURY.*

*WEBSITE FOR SILICOSIS:*

*<http://www.osha.gov/Silica/IT69D.1.html>*

# RPJ-2

**LARRY HESS & ASSOCIATES, INC**  
**P.O. BOX 1615**  
**SALISBURY, NC 28145-1615**  
**TOLL 1-800-535-2612 / FAX 704-636-9311**  
**[www.blast-it-all.com](http://www.blast-it-all.com) OR [sales@blast-it-all.com](mailto:sales@blast-it-all.com)**

## Table of Contents

<i>Specifications and Instructions .....</i>	<i>1-2</i>
<i>Pre-Start Check .....</i>	<i>3</i>
<i>Operation .....</i>	<i>4</i>
<i>Maintenance .....</i>	<i>5</i>
<i>Troubleshooting.....</i>	<i>5</i>
<i>Illustration &amp; Parts List .....</i>	<i>6</i>

MM-329  
Specification and Instructions for RPJ Collectors

## 1.0 General Description

The MODEL RPJ COLLECTORS are cartridge filter jet pulse type collectors. These collectors may be supplied as a complete unit or they may be supplied in two sections ready for installation in the users plant. A top opening door is provided for the inspection and/or replacement of the filter cartridges and the air pulsing system components. If the unit is supplied with a hopper it is of the pyramidal type forming the lower part of the collector. An air inlet is located either on the side or top depending on the size of the collector. The dirty air stream passes through the inlet and is deflected away from the cartridges to help prevent premature cartridge wear. As the dirty air enters the collection chamber the velocity reduces due to the expanded area. The heavier particles drop into the Dust Drawer or Hopper. The air separates as it is drawn into the cartridge filter(s). The air goes through the cartridge media for the final separation of the solids (dirt) from the air stream. Solid particles are captured on the filter media as the air stream passes through and into the center section of the cartridge and is exhausted from the collector. Compressed air jets are used periodically to BACK FLUSH (CLEAN) the filter pleats causing the collected particles to fall down into the drawer or hopper.

## 2.0 Design Considerations

2.01 Maximum negative pressure: 12" WG.

2.02 Design operating temperature: 150 F

2.03 Compressed air supply: 80 to 90 PSIG operating pressure with a 100 PSIG being the maximum design.

## 3.0 Installation and arrangement

The user will place the unit on a flat level surface. The self-supporting base and/or structure provided does not require anchor bolts for indoor applications. If the unit is to be located outdoors, the user must provide adequate anchoring consistent with the appropriate building codes. When locating the unit, allow sufficient space to allow filter removal from the top of the unit (usually 3 feet).

## 4.0 Basic Construction

4.01 Basic Unit: The basic unit is fabricated from 12 gauge carbon steel. All seams are continuously welded to form a solid seal. The filter/air pulsing access door(s) are gasketed. The air jet valves are designed especially for this type air pulse application and are operated through the sequence control by manual push buttons or by timed unit depending on the model or the unit.

- 4.02 *Filter Cartridges:* Each cartridge contains approximately 250 pleats and the number of filter units depends of the unit size. The open end of the cartridge has a lip under which a special composition gasket is mounted. Any cuts, gouges or tears in this gasket will cause premature failure of the filtering unit.
- 4.03 *Cleaning Control:* The cleaning us actuated by a one of two means. On the manual cleaning units a manual push-button is provided. On the larger units a solid state controller it provided. On some units this control may be shipped loose for installation by the customer.

## 5.0 *Reverse Pulse Jet Air System*

The compressed air manifold is to be supplied with compressed air at 85 PSIG. The user must provide a pressure regulator to maintain this pressure. The air supply must be clean and free of moisture. Air consumption rates for 85 PSIG are determined as follows in standard cubic feet of compressed air:

*Number of pulse valves (cartridges) x 1.75 SCF*

*Example: 2 cartridges x 1.75 SCF= 3.5 SCF*

*If we clean every 3 minutes the usage is divided by 3 or 1.16 SCFM.*

## 6.0 *Paint*

*One coat of primer is applied to all interior and exterior surfaces. A finish coat of industrial enamel is applied to the exterior.*

## 7.0 *Shipment*

*The smaller units without hopper(s) are shipped assembled. The units with hoppers are shipped in two sections. The filters, filters hold-downs, and control box require field installation.*

## 8.0 *Compressed Air Piping*

*The compressed air piping installed by the user shall be a minimum of 1/2" sch 40. **In addition a pressure regulator must be provided and installed by the user.***

## Pre-Start Check

### 1.0 Pre Start Checklist

*Review all components to assure that they are operational.*

- 1.01 **All Ductwork** - The inlet and exhaust ducting must be inspected to assure it is properly installed and complete.
- 1.02 **Dust Drawer / Hopper Gaskets** - The gasket on the drawer edge must be installed and attached to the drawer. This drawer must be closed and secured before operation.
- 1.03 **Compressed Air Piping** - A pressure regulator must be installed and set for 85 PSI. Make sure the air is clean and dry.
- 1.04 **Wiring** - Motors must be wired and installed with proper overload protection.
- 1.05 **Sequence Control Box** - Provide incoming wiring. Control will be pre-set. The control box is to be field installed.
- 1.06 **Electrical Protection Devices** - Fuses, circuit, breakers, heaters, etc., must be properly sized and installed.
- 1.07 **System Fan** - Make sure the rotation of the fan is correct.

## Operation

### 1.0 Start-Up and Operation

1.01 Turn on compressed air supply.

1.02 Start system: CHECK FAN ROTATION

1.03 Check seals.

### 2.0 Filter Cleaning

2.01 If the unit is equipped with automatic pulse cleaning, the cleaning cycle will be timer and activated when the unit is in operation.

2.02 If the unit is not equipped with a automatic pulse package, the filters are cleaned by manually pushing the clean pulse air valve. This will allow the cartridge to be pulse cleaned. **(PULSE AND RELEASE)**  
**THIS NEEDS TO BE OPERATED AT LEAST ONCE EACH HOUR OF OPERATION OR MORE IF A DIRTY CABINET CONDITION EXISTS.**

### 3.0 Dust Drawer / Hopper Emptying

The collector must be shut down before any attempt is made to empty the dust container.

3.01 Shut system down

3.02 Un-latch dust drawer / hopper.

3.03 Remove and empty container in to approved dust receptacle.

3.04 Replace drawer or container and secure.

**NOTE: MAKE SURE GASKET SEAL IS IN PLACE.**

## Maintenance

*Regular maintenance is consistent with satisfactory and efficient operation of any dust collector. Remember to clean and inspect the filter regularly and do not allow the dust container(s) to overfill.*

### 1.0 Weekly

1.01 *Compressed air pressure set at 85 PSI.*

1.02 *Drain all moisture from compressed air lines.*

1.03 *Check and record pressure drop across the filters with customer supplied manometer.*

1.04 *Empty dust container. The container may have to be emptied more frequently depending on use.*

### 2.0 Monthly

2.01 *Inspect dust container gasket(s).*

2.02 *Remove and inspect filter cartridge.*

2.03 *Replace cartridge if evidence of dirt is inside.*

### 3.0 Yearly

3.01 *Check all gaskets and replace if required.*

3.02 *Remove all cartridges and inspect for wear. If evidence of dirt is inside replace filters.*

### 4.0 Filter Removal

4.01 *Open filter access area.*

4.02 *Remove filter hold-down device.*

4.03 *Pull out filters "being careful not to knock off dust into clean air area"*

### 5.0 Filter Cartridge Replacement

5.01 *Brush any dust that may have fallen into the clean air compartment into the dust bin. Remove any bits of the old filter gasket that may have stuck to the filter plate.*

5.02 *Slowly place cartridges in holes.*

5.03 *Replace the hold-down bars and attach with the holding nuts. Maintain even pressure at all points.*

5.04 *Close collector.*

## Troubleshooting

### 1.0 Visibility poor in cabinet

#### 1.01 Pulse Interval Time Too Long:

Adjust the knob in the sequence control panel to shorter time. (The larger unit the shorter the time required).

#### 1.02 Filter(s) Wet:

Make sure there is not moisture in the compressed air lines.

#### 1.03 Filter(s) Blinded:

- A. Blinded filters can be the result of operating the unit too long without cleaning or the cleaning interval is too long.
- B. The dust drawer or bin is over full. A full bin will cause severe dust reintrainment, which will overload (blind) the filters. Remove the filters from the unit and clean or replace.

### 2.0 Control Circuit Fails to Operate:

2.01 If the diaphragm valve does not operate, this generally indicates a leak in the tubing. If the control tube has a leak the diaphragm valve will remain open and no pressure will build up in the log manifold.

2.02 Compressed Air Bleed Down: If a diaphragm valve will not return to the closed position, this indicates either a break in the diaphragm, a leaking control line, or a control pulse solenoid is stuck in the open position.

2.03 Check to make sure there is sufficient air pressure flow to the log manifold.

### 3.0 Puff or Dust Out Exhaust After Each Cleaning:

3.01 Cleaning too often: Clean less often or increase the interval on the control panel.

3.02 Filter Worn: Remove and inspect filters for pin holes, spots, or other locations where dust may be passing through the filter media. Replace filter cartridges if required.

4.0 *Continuous Dust Out Exhaust:*

4.01 *Broken, torn, or punctured filter media. Locate and replace cartridge.*

4.02 *Poor seal between cartridge and collector plate: Look for dust patterns around the filter seals. Re-tighten or replace filter. Do not attempt to repair gasket seal.*

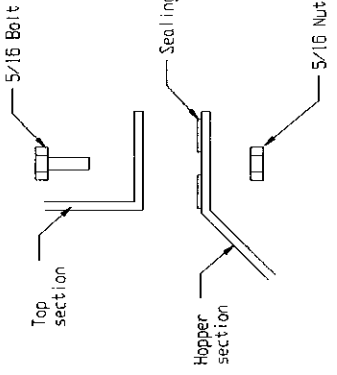
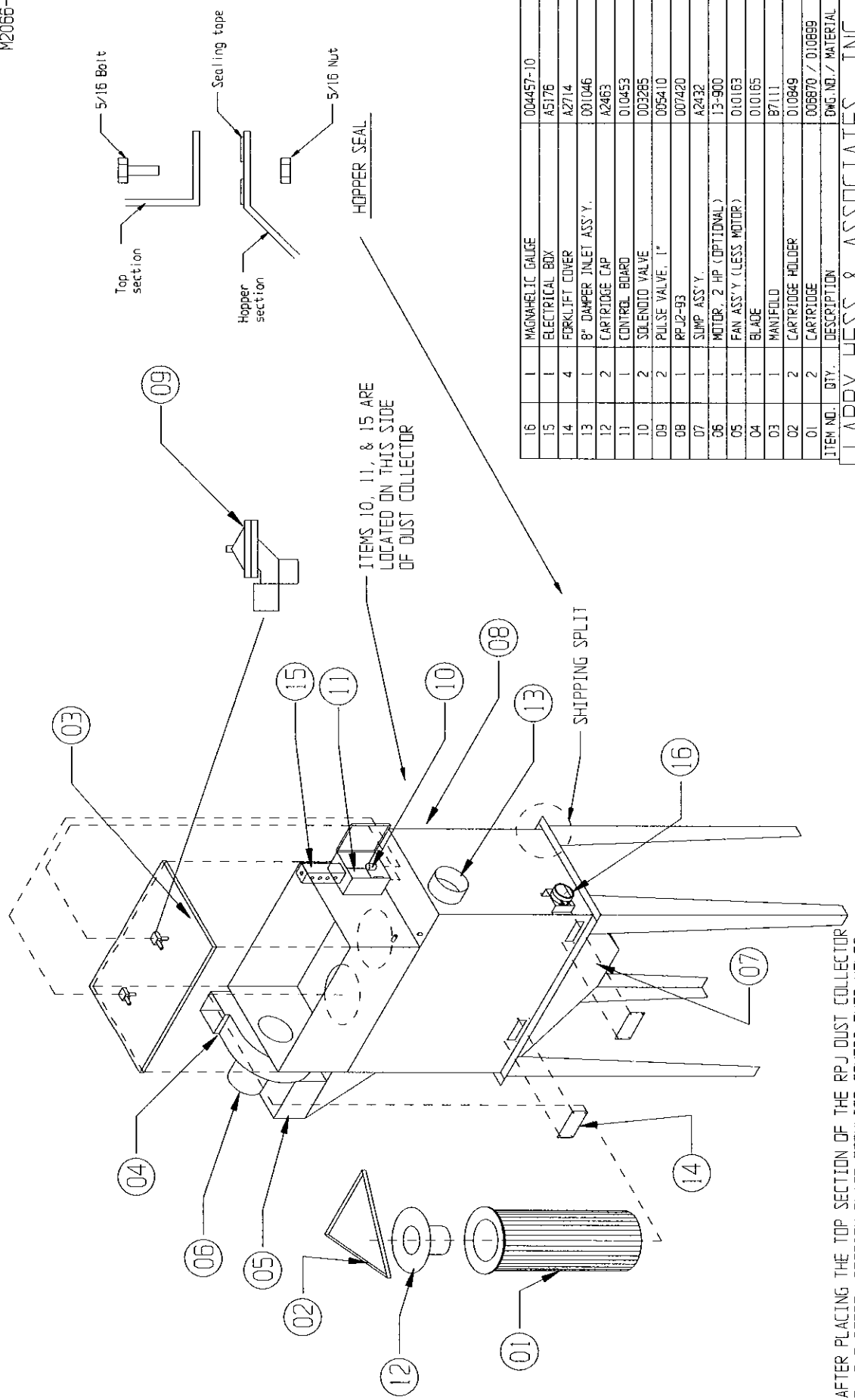

16	1	MAGNETIC GAUGE	004457-10
15	1	ELECTRICAL BOX	A5176
14	4	FORKLIFT COVER	A2714
13	1	8" DAMPER INLET ASS'Y.	001046
12	2	CARTRIDGE CAP	A2463
11	1	CONTROL BOARD	010453
10	2	SOLENOID VALVE	003285
09	2	PULSE VALVE, 1"	005410
08	1	RPJ2-93	007420
07	1	SUMP ASS'Y.	A2432
06	1	MOTOR, 2 HP (OPTIONAL)	13-900
05	1	FAN ASS'Y (LESS MOTOR)	010163
04	1	BLADE	010165
03	1	MANIFOLD	B7111
02	2	CARTRIDGE HOLDER	010849
01	2	CARTRIDGE	006870 / 010899
ITEM NO. QTY. DESCRIPTION			ENG. NO. / MATERIAL

LARRY HESS & ASSOCIATES, INC.  
SALISBURY, NORTH CAROLINA

DESCRIPTION: 2 CARTRIDGE DUST COLLECTOR (900 CFM)  
MATERIAL: 14 GA.

DATE: 04-22-93  
DRAWN BY: DEC  
CHECKED BY: [blank]  
SCALE: 3/4" = 1"  
REV. DATE DESCRIPTION BY DATE

**CONFIDENTIAL**

THE DISCLOSURE AND CONTENTS OF THIS DRAWING ARE CONFIDENTIAL AND ARE THE EXCLUSIVE PROPERTY OF LARRY HESS & ASSOCIATES, INC. THIS DRAWING IS NOT TO BE COPIED OR REPRODUCED WHOLLY OR IN PART WITHOUT WRITTEN PERMISSION OF LARRY HESS & ASSOCIATES, INC.

\*NOTE: AFTER PLACING THE TOP SECTION OF THE RPJ DUST COLLECTOR ON THE BOTTOM SECTION PLACE FORKLIFT COVERS OVER HOLES. USE PUTTY TAPE BETWEEN ALL BOLT TOGETHER FLANGES.

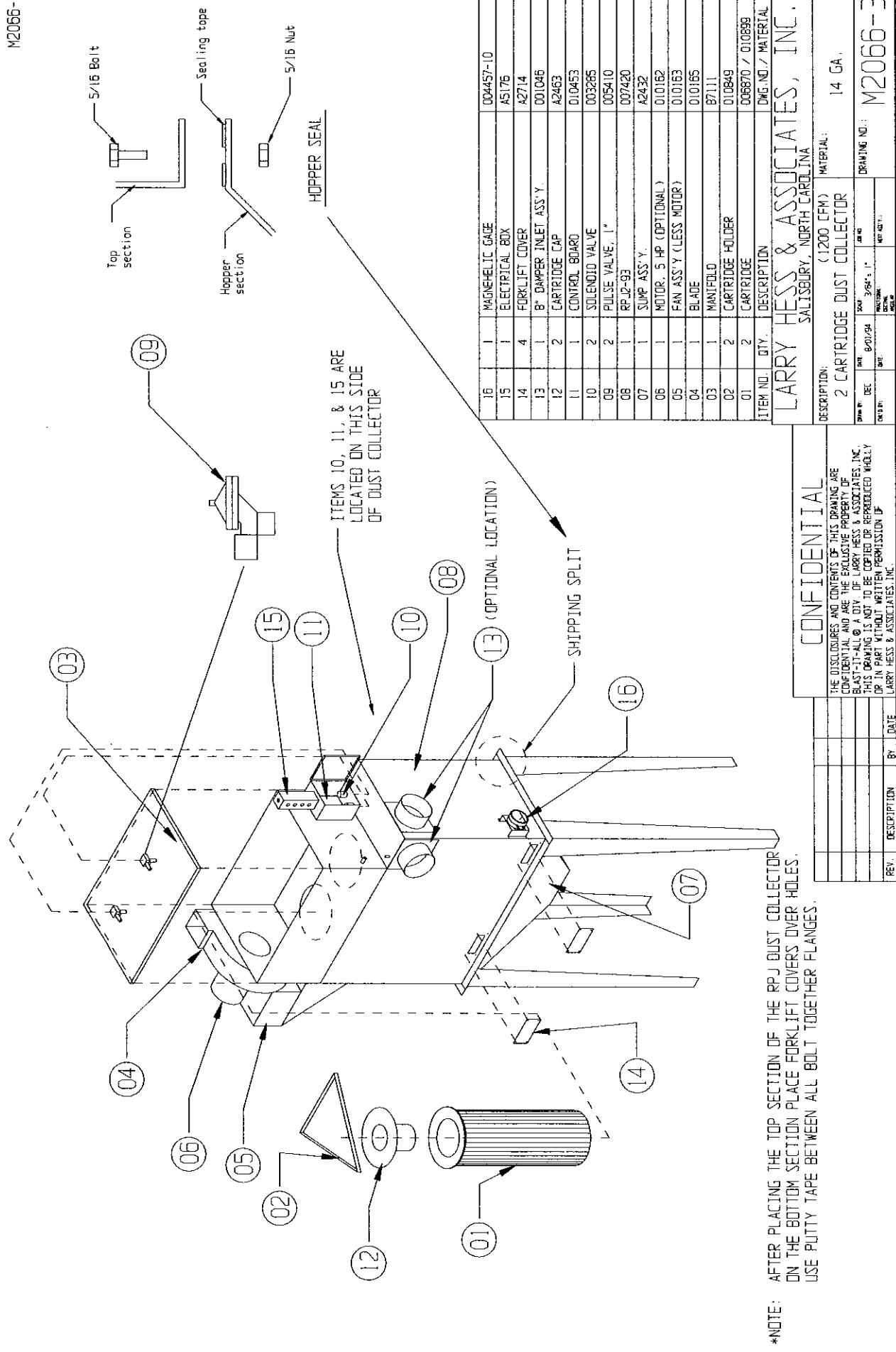

ITEMS 10, 11, & 15 ARE LOCATED ON THIS SIDE OF DUST COLLECTOR

\*NOTE: AFTER PLACING THE TOP SECTION OF THE RPJ DUST COLLECTOR ON THE BOTTOM SECTION PLACE FORKLIFT COVERS OVER HOLES. USE PUTTY TAPE BETWEEN ALL BOLT TOGETHER FLANGES.

ITEM NO.	QTY.	DESCRIPTION	DWG. NO. / MATERIAL
16	1	MAGNETIC GAGE	004457-10
15	1	ELECTRICAL BOX	A5176
14	4	FORKLIFT COVER	A2714
13	1	8" DAMPER INLET ASS'Y.	010446
12	2	CARTRIDGE CAP	A2463
11	1	CONTROL BOARD	010453
10	2	SOLENOID VALVE	03286
09	2	PULL SE VALVE, 1"	005410
08	1	RPJ-93	007420
07	1	SUMP ASS'Y.	A2432
06	1	MOTOR, 5 HP (OPTIONAL)	010162
05	1	FAN ASS'Y (LESS MOTOR)	010163
04	1	BLADE	010165
03	1	MANIFOLD	87111
02	2	CARTRIDGE HOLDER	010849
01	2	CARTRIDGE	006870 / 010899
		DESCRIPTION	DWG. NO. / MATERIAL

LARRY HESS & ASSOCIATES, INC.  
 SALISBURY, NORTH CAROLINA  
 DESCRIPTION: (1200 CFM)  
 2 CARTRIDGE DUST COLLECTOR  
 MATERIAL: 14 GA.  
 DATE: DEC 80/94  
 DRAWN BY: [ ]  
 CHECKED BY: [ ]  
 REV. DESCRIPTION BY DATE

CONFIDENTIAL

THE DISCLOSURES AND CONTENTS OF THIS DRAWING ARE CONFIDENTIAL AND ARE THE EXCLUSIVE PROPERTY OF LARRY HESS & ASSOCIATES, INC. THIS DRAWING IS NOT TO BE COPIED OR REPRODUCED WHOLLY OR IN PART WITHOUT WRITTEN PERMISSION OF LARRY HESS & ASSOCIATES, INC.

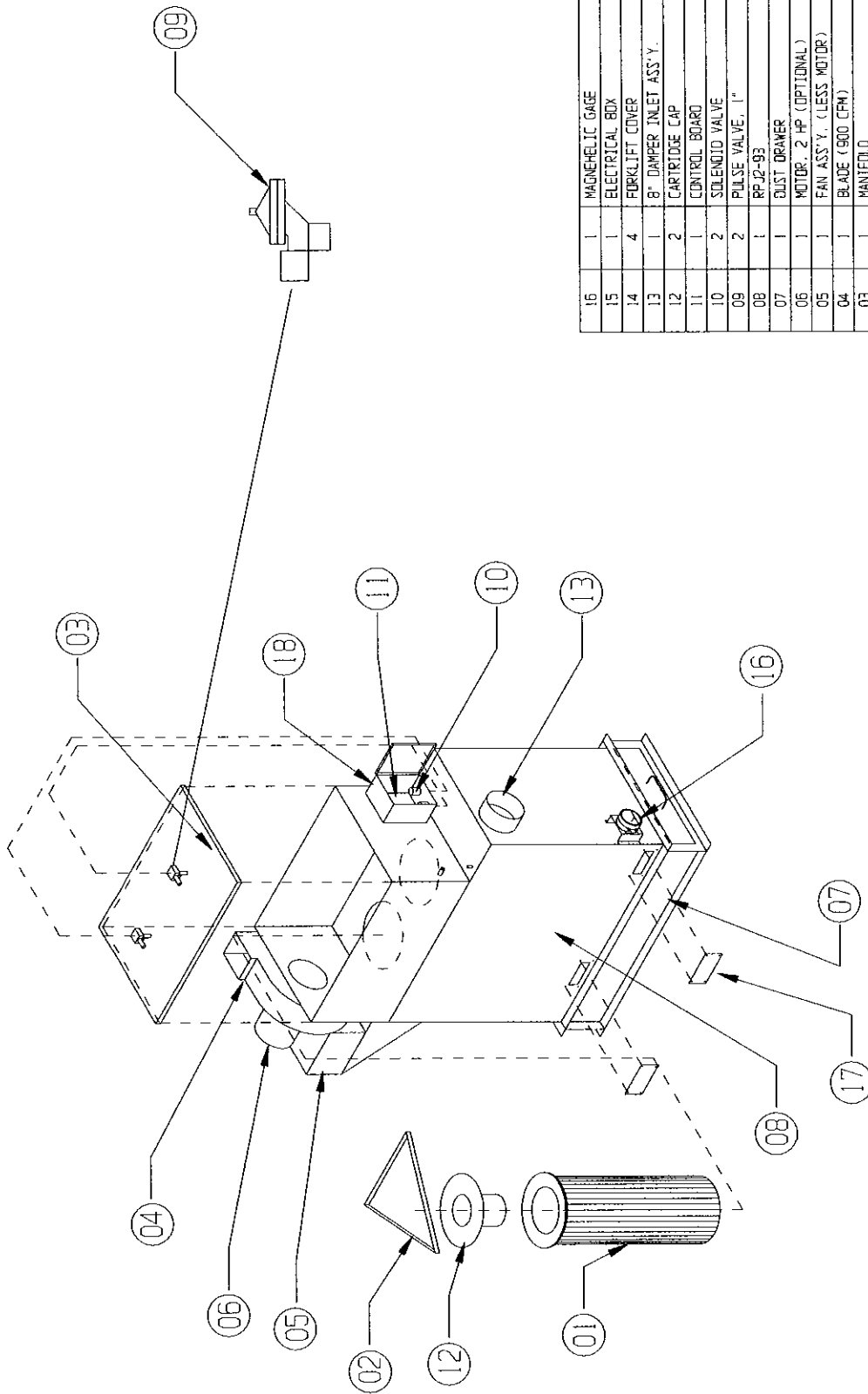

\*NOTE: AFTER PLACING THE TOP SECTION OF THE RPJ DUST COLLECTOR ON THE BOTTOM SECTION PLACE FORKLIFT COVERS OVER HOLES. USE PUTTY TAPE BETWEEN ALL BOLT TOGETHER FLANGES.

**CONFIDENTIAL**

THE DISCLOSURES AND CONTENTS OF THIS DRAWING ARE CONFIDENTIAL AND ARE THE EXCLUSIVE PROPERTY OF LARRY HESS & ASSOCIATES, INC. ALL RIGHTS RESERVED. IT IS NOT TO BE COPIED OR REPRODUCED WHOLLY OR IN PART WITHOUT WRITTEN PERMISSION OF LARRY HESS & ASSOCIATES, INC.

REV.	DESCRIPTION	BY	DATE
#1	UPDATED TO 900	DEC	03/22/05
#2	UPDATED	DEC	02/28/07

ITEM NO.	QTY.	DESCRIPTION	DWG. NO. / MATERIAL
16	1	MAGNETIC GAGE	004457-10
15	1	ELECTRICAL BOX	AS175
14	4	FORKLIFT COVER	A2714
13	1	8" DAMPER INLET ASS'Y.	001046
12	2	CARTRIDGE CAP	A2463
11	1	CONTROL BOARD	010453
10	2	SOLENOID VALVE	003285
09	2	PULSE VALVE, 1"	005410
08	1	RPJ-93	007420
07	1	DUST DRAWER	
06	1	MOTOR, 2 HP (OPTIONAL)	000077
05	1	FAN ASS'Y. (LESS MOTOR)	001062
04	1	BLADE (900 CFM)	001054
03	1	MANIFOLD	B7111
02	2	CARTRIDGE HOLDER	
01	2	CARTRIDGE	006870

DESCRIPTION: (900 CFM)  
 2 CARTRIDGE DUST COLLECTOR

LARRY HESS & ASSOCIATES, INC.  
 SALISBURY, NORTH CAROLINA

MATERIAL: 14 GA.  
 DRAWING NO.: M2068-1

DATE	BY	CHKD.	DATE
DEC 03/22/05		DEC 03/22/05	
DEC 02/28/07		DEC 02/28/07	

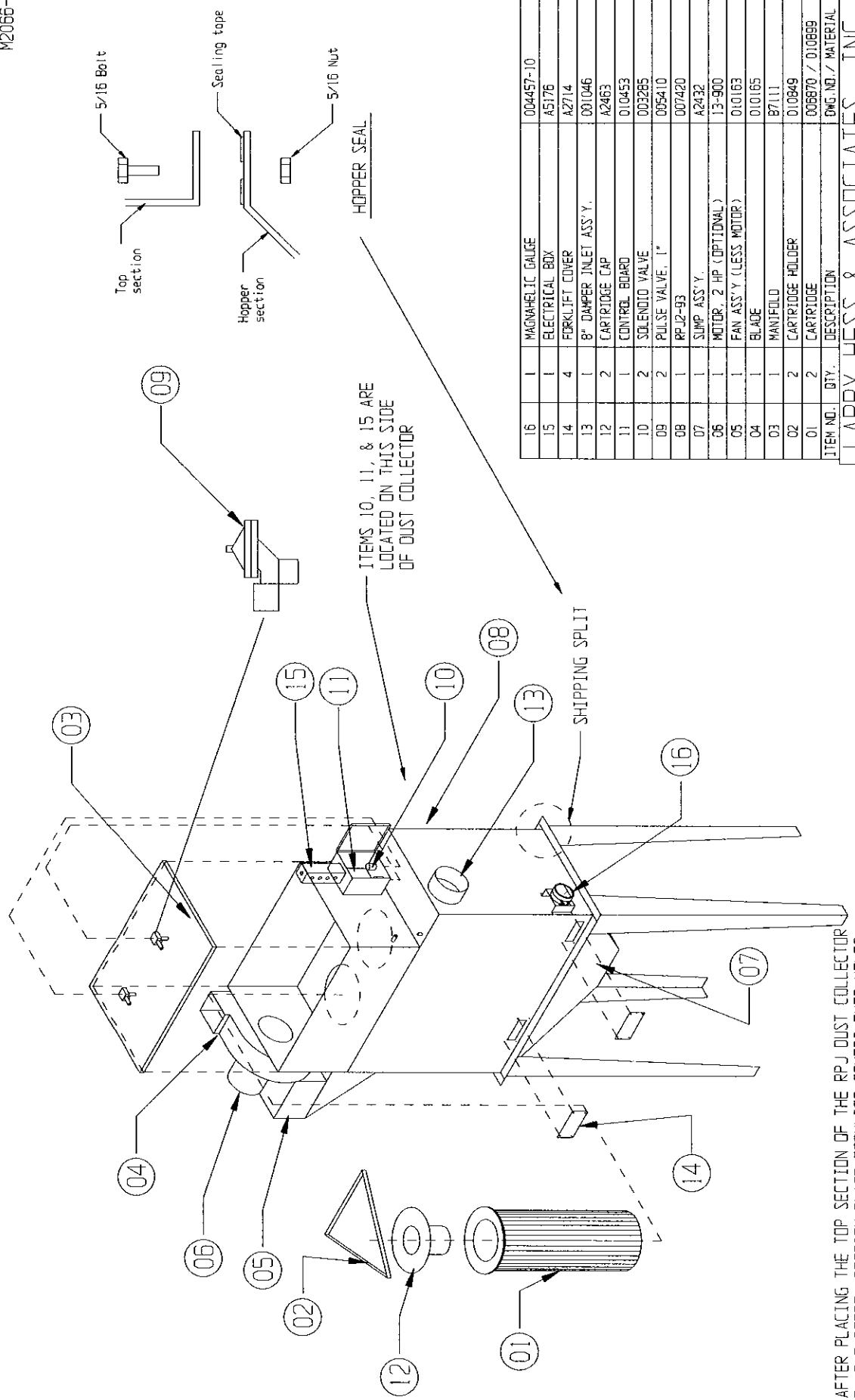

ITEM NO.	QTY.	DESCRIPTION	ENG. NO. / MATERIAL
16	1	MAGNETIC GAUGE	004457-10
15	1	ELECTRICAL BDX	A5176
14	4	FORKLIFT COVER	A2714
13	1	8" DAMPER INLET ASS'Y.	001046
12	2	CARTRIDGE CAP	A2463
11	1	CONTROL BOARD	010453
10	2	SOLENOID VALVE	003285
09	2	PULSE VALVE, 1"	005410
08	1	RPJ2-93	007420
07	1	SUMP ASS'Y.	A2432
06	1	MOTOR, 2 HP (OPTIONAL)	13-900
05	1	FAN ASS'Y (LESS MOTOR)	010163
04	1	BLADE	010165
03	1	MANIFOLD	B7111
02	2	CARTRIDGE HOLDER	010849
01	2	CARTRIDGE	006870 / 010899

**LARRY HESS & ASSOCIATES, INC.**  
 SALISBURY, NORTH CAROLINA

DESCRIPTION: 2 CARTRIDGE DUST COLLECTOR (900 CFM)  
 MATERIAL: 14 GA.

DATE: 04-22-93  
 DRAWN BY: DEC  
 CHECKED BY: [blank]

REV.	DESCRIPTION	BY	DATE

**CONFIDENTIAL**

THE DISCLOSURE AND CONTENTS OF THIS DRAWING ARE CONFIDENTIAL AND ARE THE EXCLUSIVE PROPERTY OF BLAST-IT-ALL @ A DIV. OF LARRY HESS & ASSOCIATES, INC. THIS DRAWING IS NOT TO BE COPIED OR REPRODUCED WHOLLY OR IN PART WITHOUT WRITTEN PERMISSION OF LARRY HESS & ASSOCIATES, INC.

\*NOTE: AFTER PLACING THE TOP SECTION OF THE RPJ DUST COLLECTOR ON THE BOTTOM SECTION PLACE FORKLIFT COVERS OVER HOLES. USE PUTTY TAPE BETWEEN ALL BOLT TOGETHER FLANGES.

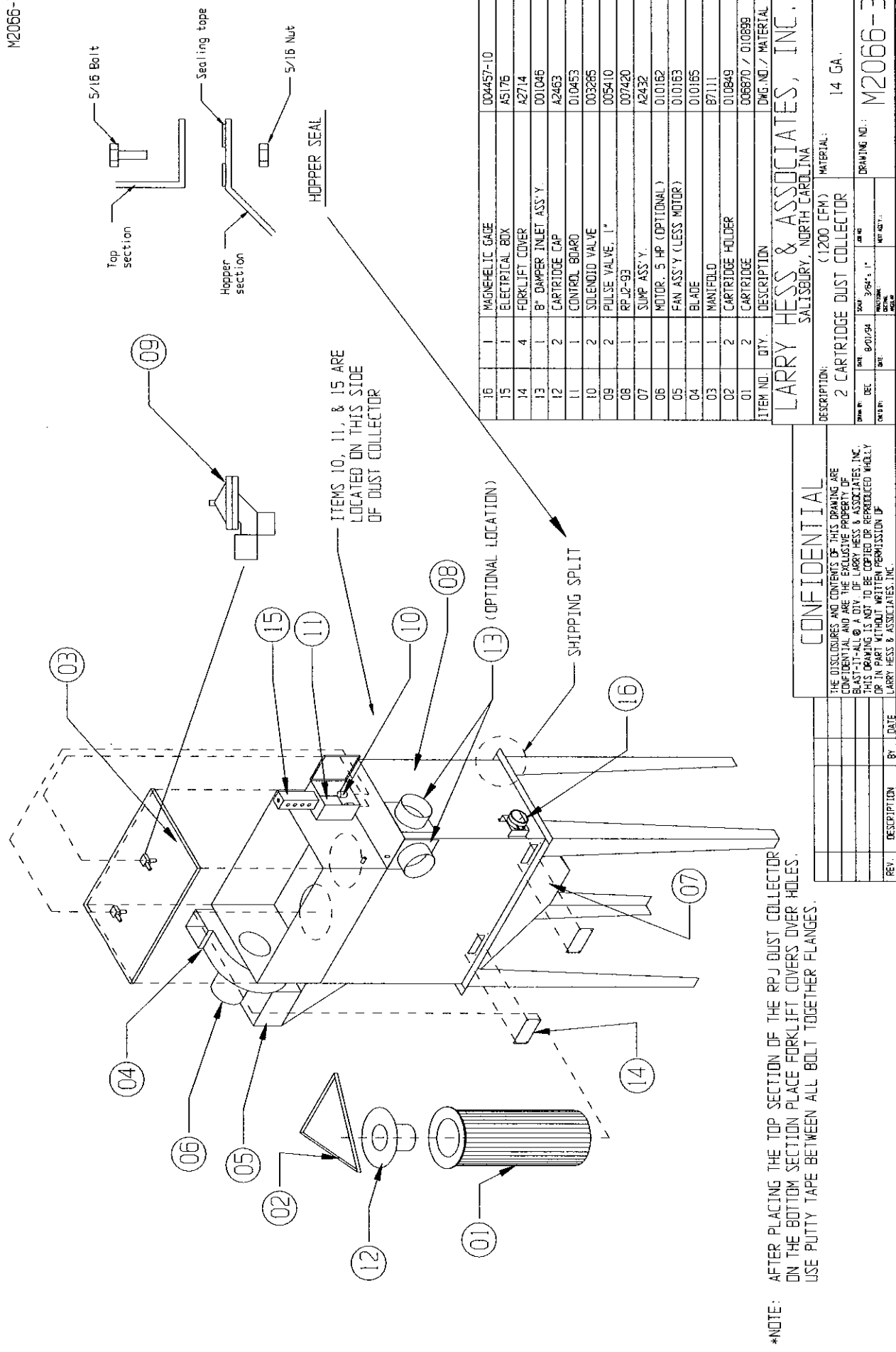

ITEM NO.	QTY.	DESCRIPTION	DWG. NO. / MATERIAL
16	1	MAGNETIC GAGE	004457-10
15	1	ELECTRICAL BOX	A5176
14	4	FORKLIFT COVER	A2714
13	1	8" DAMPER INLET ASS'Y.	010446
12	2	CARTRIDGE CAP	A2463
11	1	CONTROL BOARD	010453
10	2	SOLENOID VALVE	03286
09	2	PULL SE VALVE, 1"	005410
08	1	RPJ2-93	007420
07	1	SUMP ASS'Y.	A2432
06	1	MOTOR, 5 HP (OPTIONAL)	010162
05	1	FAN ASS'Y (LESS MOTOR)	010163
04	1	BLADE	010165
03	1	MANIFOLD	87111
02	2	CARTRIDGE HOLDER	010849
01	2	CARTRIDGE	006870 / 010899
			DWG. NO. / MATERIAL

**LARRY HESS & ASSOCIATES, INC.**  
 SALISBURY, NORTH CAROLINA

DESCRIPTION:  
 (1200 CFM)  
 2 CARTRIDGE DUST COLLECTOR

MATERIAL:  
 14 GA.

DATE: DEC 80/94  
 DRAWN BY: [ ]  
 CHECKED BY: [ ]  
 DATE: [ ]  
 DRAWING NO.: M2066-3

**CONFIDENTIAL**

THE DISCLOSURES AND CONTENTS OF THIS DRAWING ARE CONFIDENTIAL AND ARE THE EXCLUSIVE PROPERTY OF BLAST-IT-ALL © A DIV. OF LARRY HESS & ASSOCIATES, INC. THIS DRAWING IS NOT TO BE COPIED OR REPRODUCED WHOLLY OR IN PART WITHOUT WRITTEN PERMISSION OF LARRY HESS & ASSOCIATES, INC.

REV.	DESCRIPTION	BY	DATE

\*NOTE: AFTER PLACING THE TOP SECTION OF THE RPJ DUST COLLECTOR ON THE BOTTOM SECTION PLACE FORKLIFT COVERS OVER HOLES. USE PUTTY TAPE BETWEEN ALL BOLT TOGETHER FLANGES.

A2509

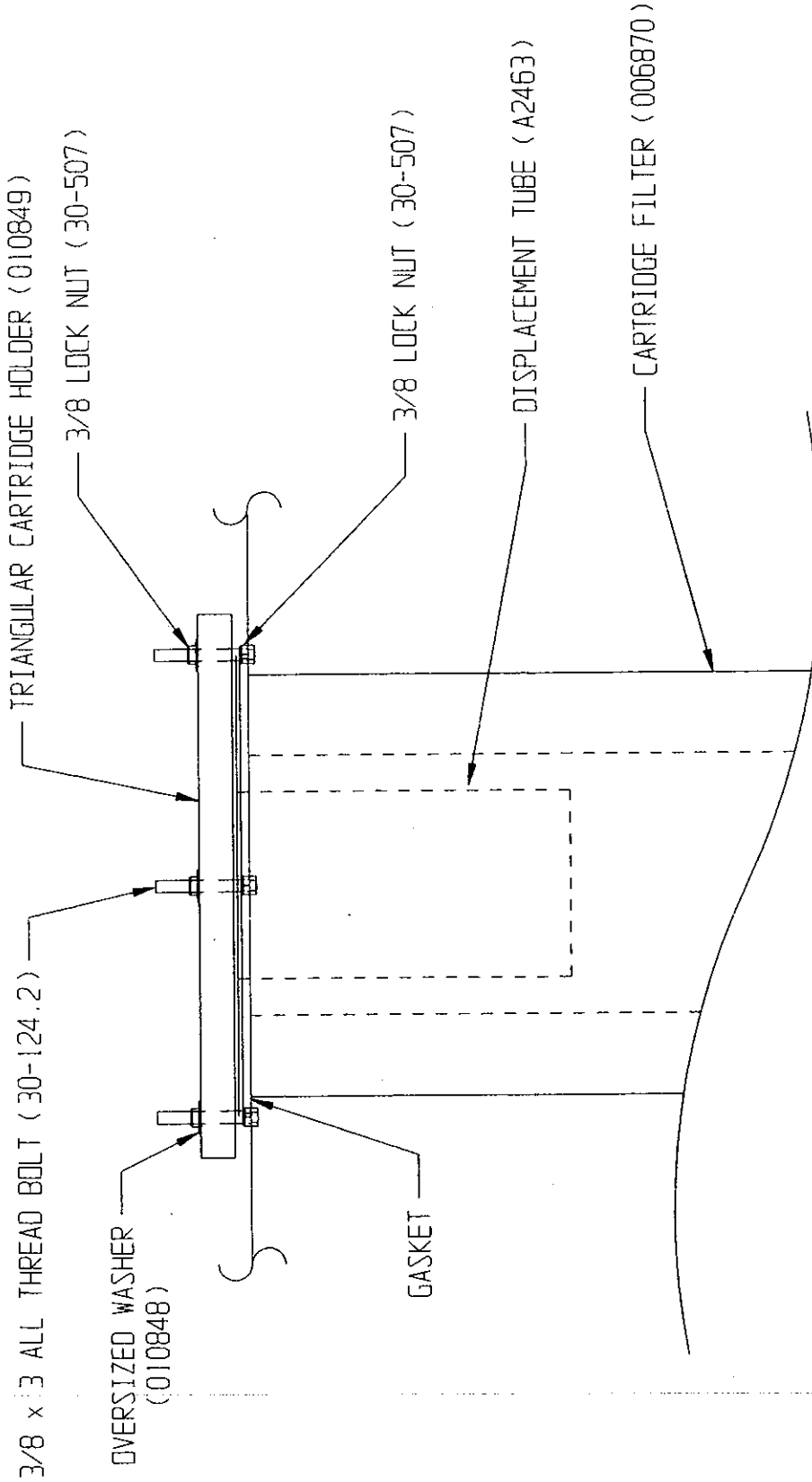

LARRY HESS & ASSOCIATES, INC.  
SALISBURY, NORTH CAROLINA

DESCRIPTION:		MATERIAL:	
RPJ CARTRIDGE INSTALLATION		PER DWG.	
DATE:	SCALE:	JOB NO.:	DRAWING NO.:
6/02/95	3/16" = 1"		A2509
DATE:	FRACTIONAL:	DECIMAL:	

**CONFIDENTIAL**

THE DISCLOSURES AND CONTENTS OF THIS DRAWING ARE CONFIDENTIAL AND ARE THE EXCLUSIVE PROPERTY OF BLAST-IT-ALL (tn) A DIV. OF LARRY HESS & ASSOCIATES, INC. THIS DRAWING IS NOT TO BE COPIED OR REPRODUCED WHOLLY OR IN PART WITHOUT WRITTEN PERMISSION OF LARRY HESS & ASSOCIATES, INC.

REV.	DESCRIPTION	BY	DATE
1	ADDED DISP. TUBE	DEC	02/03/97

B7111

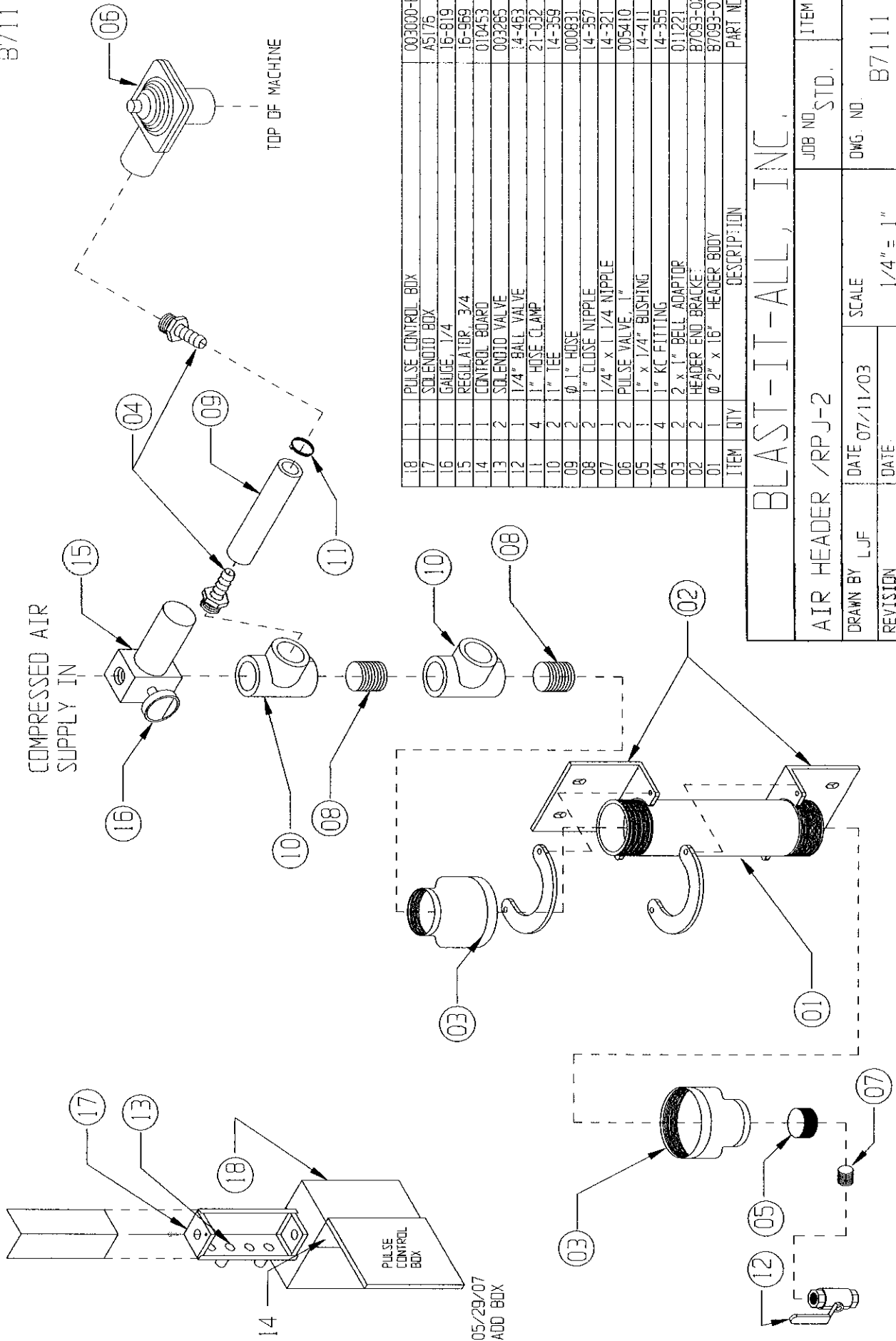

ITEM	QTY	DESCRIPTION	PART NO.
18	1	PULSE CONTROL BOX	003000-E
17	1	SOLENOID BOX	A5176
16	1	GAUGE, 1/4"	16-819
15	1	REGULATOR, 3/4"	16-969
14	1	CONTROL BOARD	010453
13	2	SOLENOID VALVE	003285
12	1	1/4" BALL VALVE	14-463
11	4	1" HOSE CLAMP	21-032
10	2	1" TEE	14-359
09	2	Ø 1" HOSE	000631
08	2	1" CLOSE NIPPLE	14-357
07	1	1/4" x 1 1/4" NIPPLE	14-321
06	2	PULSE VALVE, 1"	005410
05	1	1" x 1/4" BUSHING	14-411
04	4	1" KC FITTING	14-355
03	2	2 x 1" BELL ADAPTOR	011221
02	2	HEADER END BRACKET	B7093-02
01	1	Ø 2" x 16" HEADER BODY	B7093-01

**BLAST-IT-ALL, INC.**

JOB NO. <b>STD.</b>		ITEM NO.
DRAWN BY <b>LJF</b>		DWG. NO. <b>B7111</b>
DATE <b>07/11/03</b>	SCALE <b>1/4" = 1"</b>	
REVISION	DATE	

05/29/07  
ADD BOX

**Magnehelic® Differential Pressure Gage**



**SPECIFICATIONS**

Dimensions: 4-3/4" dia. X 2-3/16" deep.  
 Weight: 1 lb. 2 oz.  
 Finish: Baked dark gray enamel.  
 Connections: 1/8 N.P.T. high and low pressure taps, duplicated, one pair side and one pair back.  
 Accuracy: Plus or minus 2% of full scale, at 70°F. (Model 2000-0, 3%; 2000-00, 4%).  
 Pressure Rating: 15 PSI.  
 Ambient Temperature Range: 20° to 140°F.  
 Standard gage accessories include two 1/8" N.P.T. plugs for duplicate pressure taps, two 1/8" pipe thread to rubber tubing adapters, and three flush mounting adapters with screws.



**PART NO. 004457**

**Caution:** For use with air or compatible gases only. For repeated over-ranging or high cycle rates, contact factory.

**Hydrogen Gas Precautionary Note:** The rectangular rare earth magnet used in the standard gage may not be suitable for use with hydrogen gas since a toxic and explosive gas may form. For hydrogen service, consult the factory for an alternate gage construction.

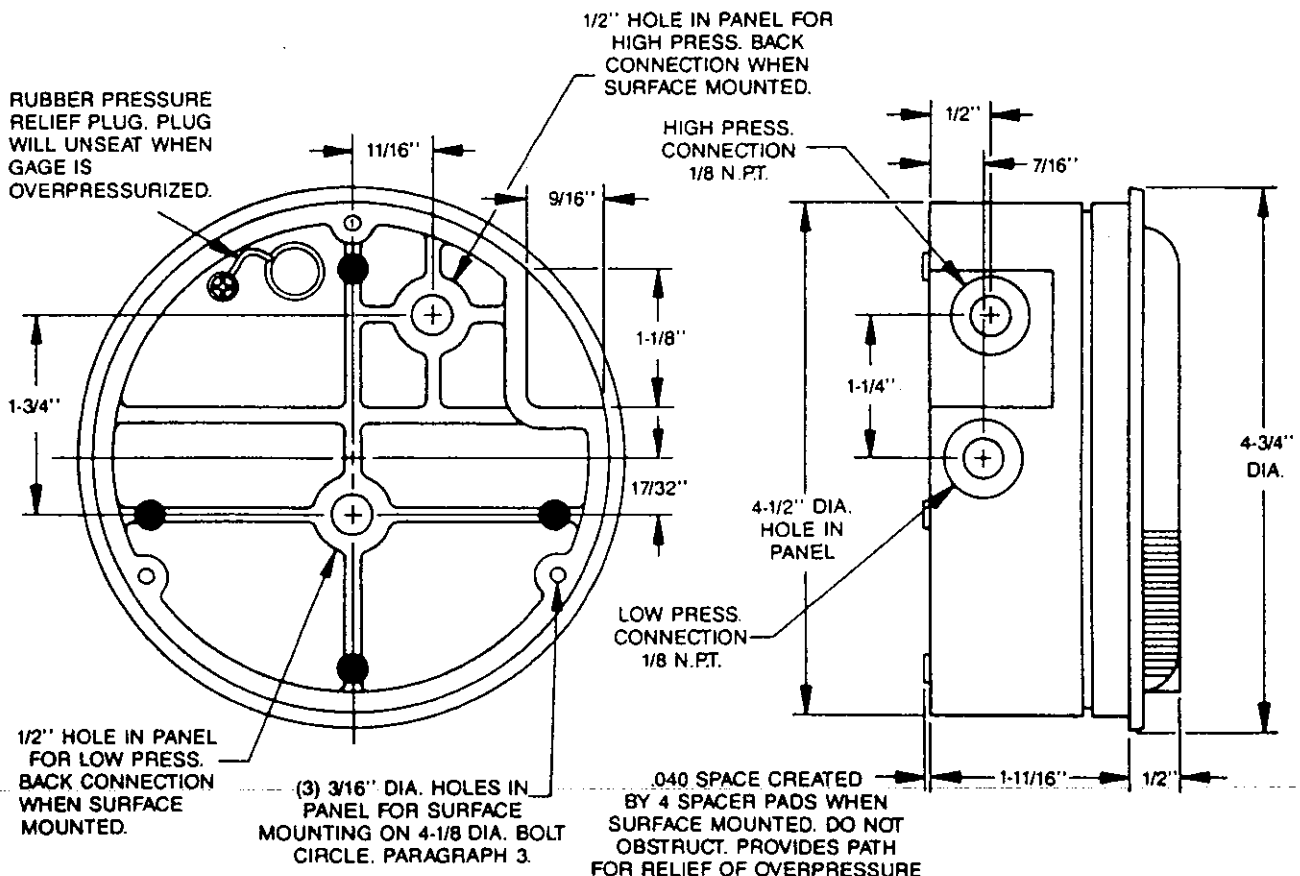



Specifications – Installation & Operating Instructions

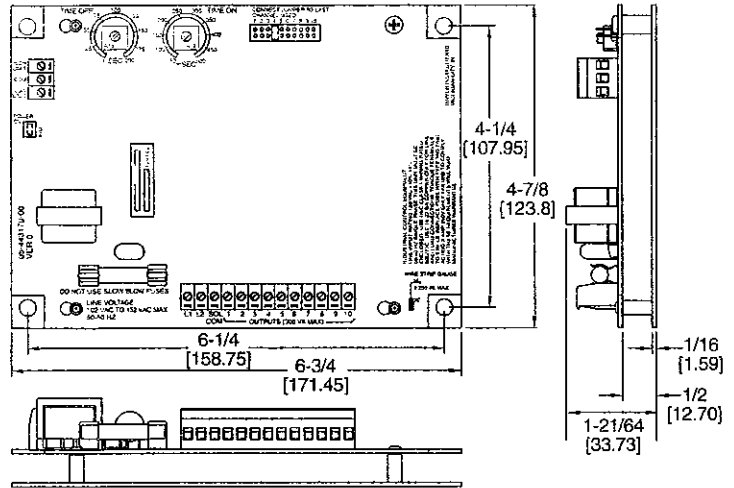
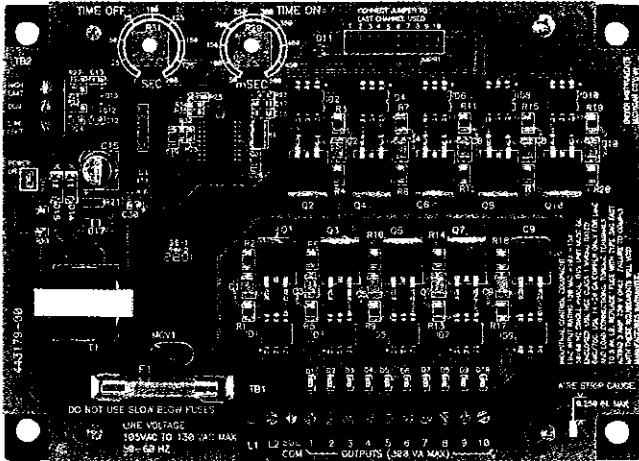

Introduction

The Series DCT 500 Timer Controller is a timing system for pulse-jet type dust collectors or pneumatic conveying systems in either continuous or on-demand cleaning applications. It is provided with either 4, 6, or 10 channels. The DCT 500 was designed for ease of installation in your dust collector system. For installations requiring fewer channels than available on the board, a shorting plug is provided to allow selection of the last used channel. Time-on and time-off settings are selected using two potentiometers. High-limit and low-limit control inputs are provided for use with on-demand systems. When used in a continuous mode the high-limit input is jumpered. For safety, the control circuitry including the control inputs and the last channel jumper, is isolated from the power line.

Installation



**Warning: Always install and service this device with the power off and a lockout installed if required.** Line voltages are exposed on the board. As a result, this device is not intended to be installed in any open location. It must be installed within an enclosure that meets appropriate safety and local code requirements. Follow applicable safety procedures when installing or servicing this product.



**Warning: Always replace the fuse with the proper type and rating.** The fuse is Type 3 AG fast acting 3 Amp @ 250V. DO NOT use slow-blow type fuses. Failure to comply with this requirement will pose a serious safety risk and will void manufacturer's warrantee.

Power Requirements

The controller is designed for operation on 120 VAC 50/60 Hz power. The input voltage must be between 102 VAC and 132 VAC either 50 or 60 Hz. The solenoid loads must be rated for 120 VAC operation.

Location

The system must be located in an enclosure that meets relevant safety standards and electrical codes. There are no other special

PHYSICAL DATA

- Storage Temperature:** -40°F to 176°F (-40°C to 80°C).
- Operating Ambient Temperature:** -40°F to 176°F (-40°C to 80°C).
- Weight:** 9 oz (255 gm).
- Power:** 102 to 132 VAC 50 or 60 Hz, 1.8W max no load power.
- Fuse:** Type 3AG, 3A @250VAC.
- Output Channels:** 4, 6, and 10 channels available.
- Solenoid supply:** 300 VA.
- On Time:** 50 msec to 500 msec.
- On Time Accuracy:** ±5% of setting.
- Off Time:** 1 second to 200 seconds.
- Off Time Accuracy:** 5% of setting.

orientation requirements. Mount it using the four mounting holes in the baseplate. The baseplate back is flush, so no special spacers are needed to accommodate obstructions except for those imposed by the location itself.

Connections

The line and solenoid connections are located at the lower edge of the board. The terminal block is a "Euro" style connector system that clamps the wire within the connector body. The connector will accept wire sizes from 14 to 22 gages. These terminals should be torqued to 5 in. lb. The connectors are specified for single connection but multiple wires may be connected to a single lug provided local codes allow this and good workmanship practices are followed. When using stranded wire, make sure that there are no "stray" strands. These pose safety hazards and may cause system failure or damage. Connect the line power to L1 and L2. Connect the solenoids between the selected output and the solenoid common. Solenoid common and L2 are internally connected. Refer to Figure 2-1. The wire should be stripped to no more than 0.25 in. A strip gauge is provided at the lower right corner of the board. Longer than this may cause shorts or expose line voltages to possible contact.

Switches connected to the control inputs at the top of the board must be isolated normally open contacts connected only to the relevant terminal and to the common terminals.

The following subparagraphs describe the external switch connections. Refer to figure 2-1 for switch connection illustration.

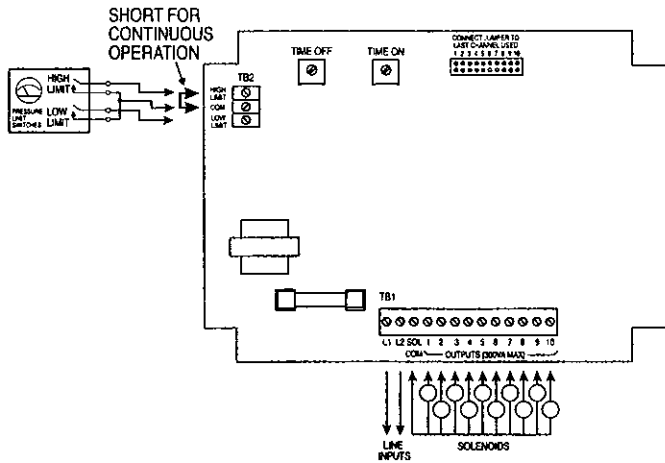

FIGURE 2-1 Switch Connections

### External Limit Switch Connection

The controller may be used with an external pressure limit switch or sensor to provide demand-cleaning operation. A three pin terminal block provides connection for external high and low limit switches. A simple on-off system can be established with a single pressure switch connected to the high limit input. Better control can be achieved with a high and low limit switch/gage such as the Dwyer Photohelic® pressure gage. The switches must be isolated contacts between the high or low limit input and the common connection. The wiring from the switches must be two or three wires with no other connections made to these. The common line must not be connected to equipment ground or protective ground, since these may introduce electrical noise and cause improper operation or possible damage to the control board. The operation of these inputs is summarized as follows:

Current Operation	Low Limit Switch	High Limit Switch	Next Operation
Hold	Open	Open	Hold
Hold or Run	X	Closed	Run
Hold	∅	Open	Hold
Hold	Closed	∅	Run
Run	Closed	≠	Run
Hold	Closed	∅	Run
Run	≠	Open	Hold

∅ — Transition from open to closed  
 ≠ — Transition closed to open  
 X — Either open or closed

### Operating Modes

#### Continuous Cycle Mode

The DCT 500 has two operating modes available for different applications. Starting with the most basic mode, it is capable of

operating in a continuous cleaning cycle. This can be initiated by placing a jumper between the high limit input and the common connection. Two setup parameters control operation: time off, time on. Time on and time off specifically deal with the solenoid on time and the time interval between the end of the on pulse and the start of the next.

### Demand Mode

Demand mode operation can be configured using the high limit and low limit inputs. A simple on-off system can be setup with a single pressure switch connected to the high limit input. Better control can be achieved with a high and low limit switch set such as is provided in the Photohelic® pressure gage. In this on-demand mode, time on and time off may be programmed to define the cleaning cycle.

### System Setup

#### Last Channel Selection

A jumper connector is provided to select the last channel used. Place the jumper on the two pins corresponding to the last channel used in the installation.

#### Time Off and Time On Setup

Time off defines the period of time between solenoid activations when no channels are enabled. This value may be set between 1 second and 200 seconds with a resolution of 1 second. Time on defines the solenoid on time. The value may be set between 50 msec and 500 msec with a resolution of 10 msec. If adjustments are made while the system is in operation, the new setting will take effect in the following solenoid cycle. Do not use excessive force to turn the potentiometers. This will damage the

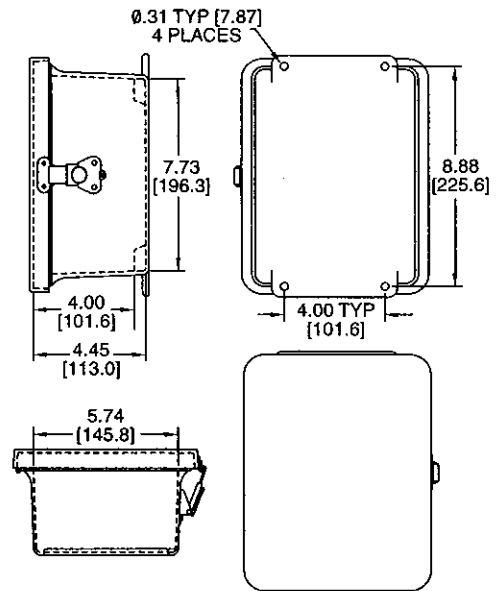

Weatherproof Enclosure Option

## WARRANTY

Larry Hess & Associates, Inc. Warrants to the original purchaser the merchandise sold to be free from defects in material and workmanship under normal use and service for a period of one (1) year. Upon prompt notification by the buyer, to LHA, components that are determined by LHA to be defective will be repaired or replaced at no additional charge, F.O.B. our factory.

Manufacturer shall have the right to inspect prior to replacing all merchandise in question.

This warranty does not apply to parts that are directly involved in the blasting operation. Example: gun, gun parts, viewing window, hose, gloves, etc.

Manufacturer shall not be required to pay any removal or installation charges whatsoever under this warranty.

Manufacturer shall not be liable for prospective profits, special or consequential damages, nor shall any recovery of any kind against manufacturer be greater in amount than the cost of repairs of defects in workmanship.

This warranty does not apply to damage caused by accidents, damage in transit, alterations by unauthorized personnel, abuse or damage by flood, fire, or acts of God, nor by artificially generated electric currents or any other cause whatsoever except defects in material or factory workmanship.

In all cases, defective parts must be returned to Larry Hess & Associates, Inc. before credit is issued.

If genuine BLAST-IT-ALL® replacement parts are not used, the warranty is void.

This warranty is in lieu of all other warranties expressed or implied and releases Larry Hess & Associates, Inc. of all other obligations and liabilities whatsoever. This warranty neither assumes nor authorizes any person to assume any obligation other than those specified by this warranty.

## WARNING

**DO NOT USE SAND. SAND WILL CAUSE SILICA DUST, WHICH IS THE CAUSE OF SILICOSIS DISEASE, A CONDITION OF MASSIVE FIBROSIS OF THE LUNGS. THIS STATEMENT INDICATES POTENTIAL PERSONNEL HAZARD. FAILURE TO COMPLY WITH THESE INSTRUCTIONS MAY RESULT IN PERSONAL INJURY.**

BLAST-IT-ALL®  
Larry Hess & Associates, Inc.  
Airport Industrial Park  
185 Piper Lane  
P.O. Box 1615  
Salisbury, NC 28145-1615