

# LITTLE BLASTER™

LARRY HESS AND ASSOCIATES, INC.

BLAST-IT-ALL®

P.O. BOX 1615

SALISBURY, NC 28145

[WWW.BLAST-IT-ALL.COM](http://WWW.BLAST-IT-ALL.COM)

**LITTLE BLASTER™**

## **LBT-3 WITH 300 CFM RECLAIM**

**MANUAL NUMBER: 506**

### **TABLE OF CONTENTS**

<b>PAGE</b>	<b>FIGURE</b>	
<b>1</b>	<b>-</b>	<b>SET-UP INSTRUCTIONS</b>
<b>1</b>	<b>-</b>	<b>OPERATING INSTRUCTIONS</b>
<b>1</b>	<b>-</b>	<b>GENERAL MAINTENANCE</b>
<b>2</b>	<b>1</b>	<b>STANDARD CABINET AND RECLAIM PARTS</b>
<b>3</b>	<b>2</b>	<b>BASKET DRIVE &amp; PARTS</b>
<b>4</b>	<b>3</b>	<b>BASKET</b>
<b>5</b>	<b>4</b>	<b>MEDIA HOSE &amp; PARTS</b>
<b>6</b>	<b>5</b>	<b>MEDIA VALVE</b>
<b>7</b>	<b>6</b>	<b>BASKET DRIVE</b>
<b>8</b>	<b>7</b>	<b>AIR CONTROL</b>
<b>9</b>	<b>8</b>	<b>BLAST GUN</b>
<b>10</b>	<b>9</b>	<b>ELECTRICAL BOX</b>
<b>11</b>	<b>10</b>	<b>ELECTRICAL DIAGRAM</b>
<b>12</b>	<b>-</b>	<b>MACHINE WARRANTY</b>

### **WARNING**

**DO NOT USE SAND.** SAND WILL CAUSE SILICA DUST, WHICH IS THE CAUSE OF SILICOSIS DISEASE, A CONDITION OF MASSIVE FIBROSIS OF THE LUNGS. THIS STATEMENT INDICATES POTENTIAL PERSONNEL HAZARD.

**FAILURE TO COMPLY WITH THESE INSTRUCTIONS  
MAY RESULT IN PERSONAL INJURY.**

WEBSITE CONCERNING SILICOSIS:

[http://www.osha.gov/Silica/IT69D\\_1.html](http://www.osha.gov/Silica/IT69D_1.html)

# LITTLE BLASTER™

## SET-UP INSTRUCTIONS

### MACHINES WITH 300 CFM RECLAIM

**\*\*\* READ BEFORE OPERATING EQUIPMENT \*\*\***

1. Remove plastic from machine.
  2. Remove lag bolts from each of the four legs, then remove machine from the pallet.
  3. Remove bag & clamp from machine.
  4. Connect compressed air supply to air filter. Air piping should be of the same size as the connection point, offering no restriction to flow.
  5. Connect the factory installed male cord from electrical box, to a 120-Volt, 60 HZ, 1 Phase power supply. A 20 AMP breaker or fuse should be used.
- (DO NOT USE QUICK-DISCONNECTS)**
- MAKE SURE MACHINE IS PROPERLY GROUNDED.**

## OPERATING INSTRUCTIONS

### 1. **Preparing parts for Blasting:**

All parts to be processed must be free of oil, grease, and moisture. Make sure parts are dry before putting into basket for cleaning.

### 2. **Air Pressure:**

5 PSI to 80 PSI. Set air pressure at 80 PSIG. Most parts for blasting cleaning cabinet should be blasted at 80 psi. Designate parts to be processed, start at lower pressure and work up the PSI scale to obtain desired finish.

**\*\*\*WARNING\*\*\***

**DO NOT CONNECT TO HIGH PRESSURE BOTTLE GAS, RUPTURE AND EXPLOSION CAN OCCUR.**

## GENERAL MAINTENANCE

### 1. **Blasting Gun:**

After 10 - 12 hours of blasting time the air orifice and nozzle should be checked. If the nozzle shows wear, rotate 1/4 turn to prevent uneven wear. If this is not checked, it could result in destruction of nozzle and damage to the gun housing. If wear is detected on the orifice tip, replace.

### 2. **Caking of Media:**

Media caking is caused by moisture in compressed air supply or oily and greasy parts. If this is not corrected, media will not flow and will clog gun. Check air supply. If water or moisture is present, install a good moisture trap. If oily or greasy parts are being blast treated, you should first degrease and dry parts.

# LB-300 CFM RECLAIMER

M1309

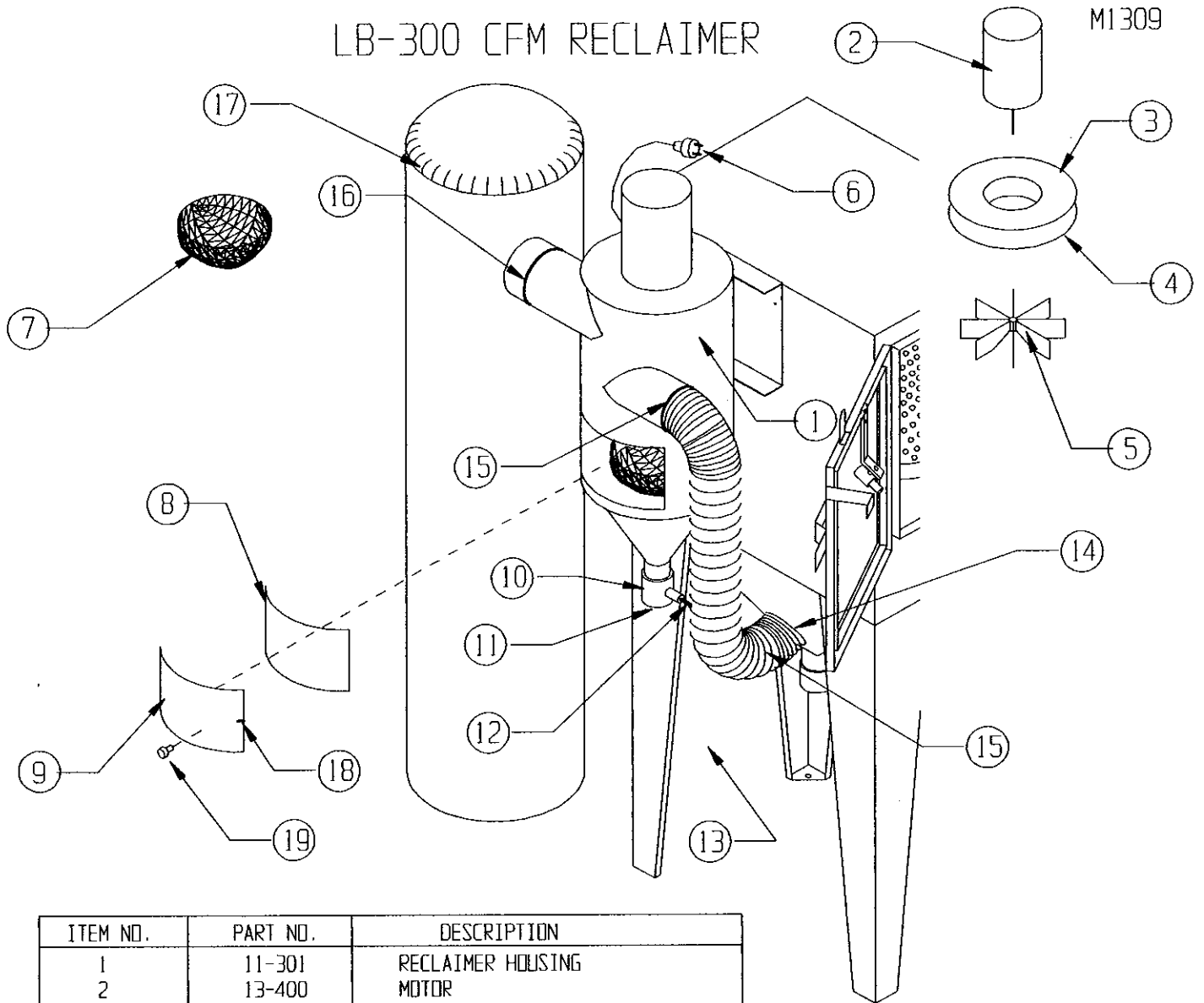

ITEM NO.	PART NO.	DESCRIPTION
1	11-301	RECLAIMER HOUSING
2	13-400	MOTOR
3	11-426	MOTOR PLATE
4	24-030	MOTOR PLATE GASKET
5	11-418	BLADE ASSEMBLY
6	13-551	MOTOR ELECTRICAL CORD & PLUG
7	11-406	TRASH SCREEN BASKET
8	11-403	RECLAIM DOOR GASKET
9	11-402	RECLAIM DOOR
10	20-200	2" MEDIA VALVE
11	20-201	2" MEDIA VALVE PLUG
12	18-084	MEDIA HOSE 5' LONG
13	19-092	4" FLEX HOSE 4' LONG
14	A590	SUMP FLEX HOSE ADAPTOR
15	21-034	FLEX HOSE CLAMPS
16	21-035	DUST BAG CLAMP
17	11-415	DUST BAG
18	15-728	RECLAIM DOOR LATCH
19	A1035	AIR INDUCER

FIGURE 1



LARRY HESS & ASSOCIATES

DESCRIPTION

LBT-3 REPLACEMENT BASKET

DATE 09/18/01

ENGINEER DEC

DWG. NO. A14080-M

SCALE: 3/16"

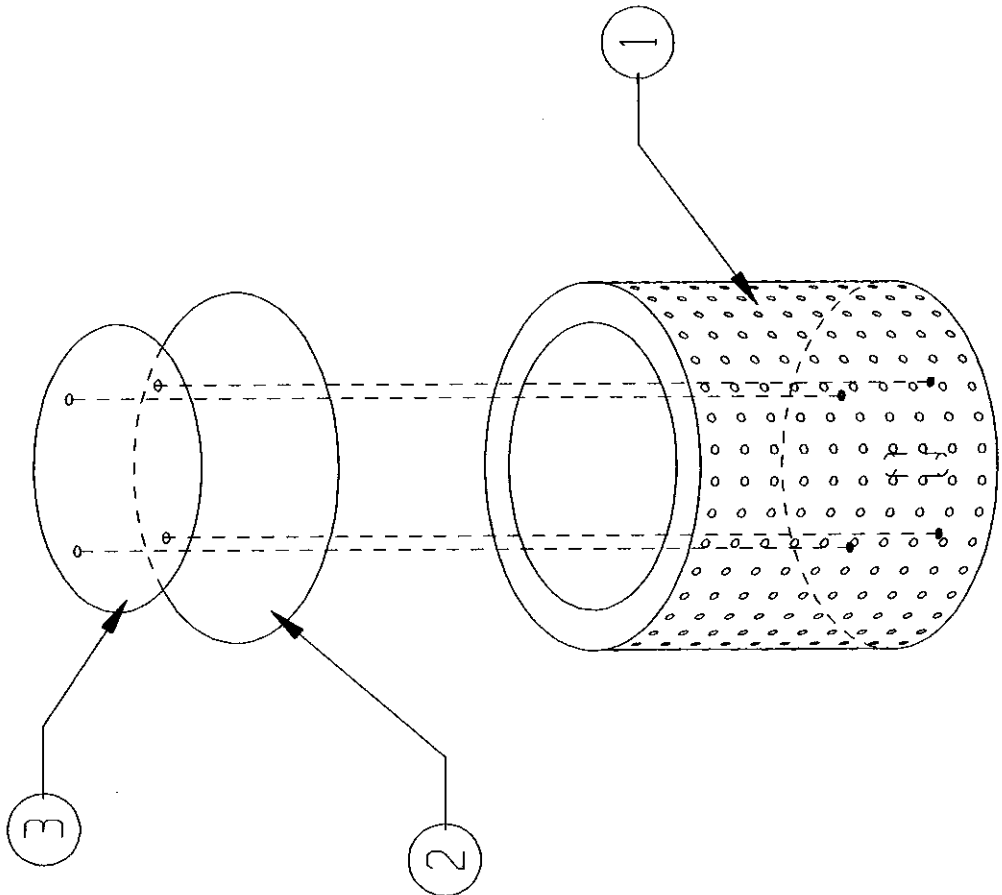

ITEM	DESCRIPTION	PART NO.	QTY.
3	WEAR PLATE	009043-5	1
2	WEAR RUBBER BOTTOM	009043-6	1
1	BASKET ASSEMBLY	009043	1

LARRY HESS & ASSOCIATES

DESCRIPTION

MEDIA SIPHON ASSEMBLY

DATE 05/30/00

ENGINEER LJF

DWG. NO. A14094-1

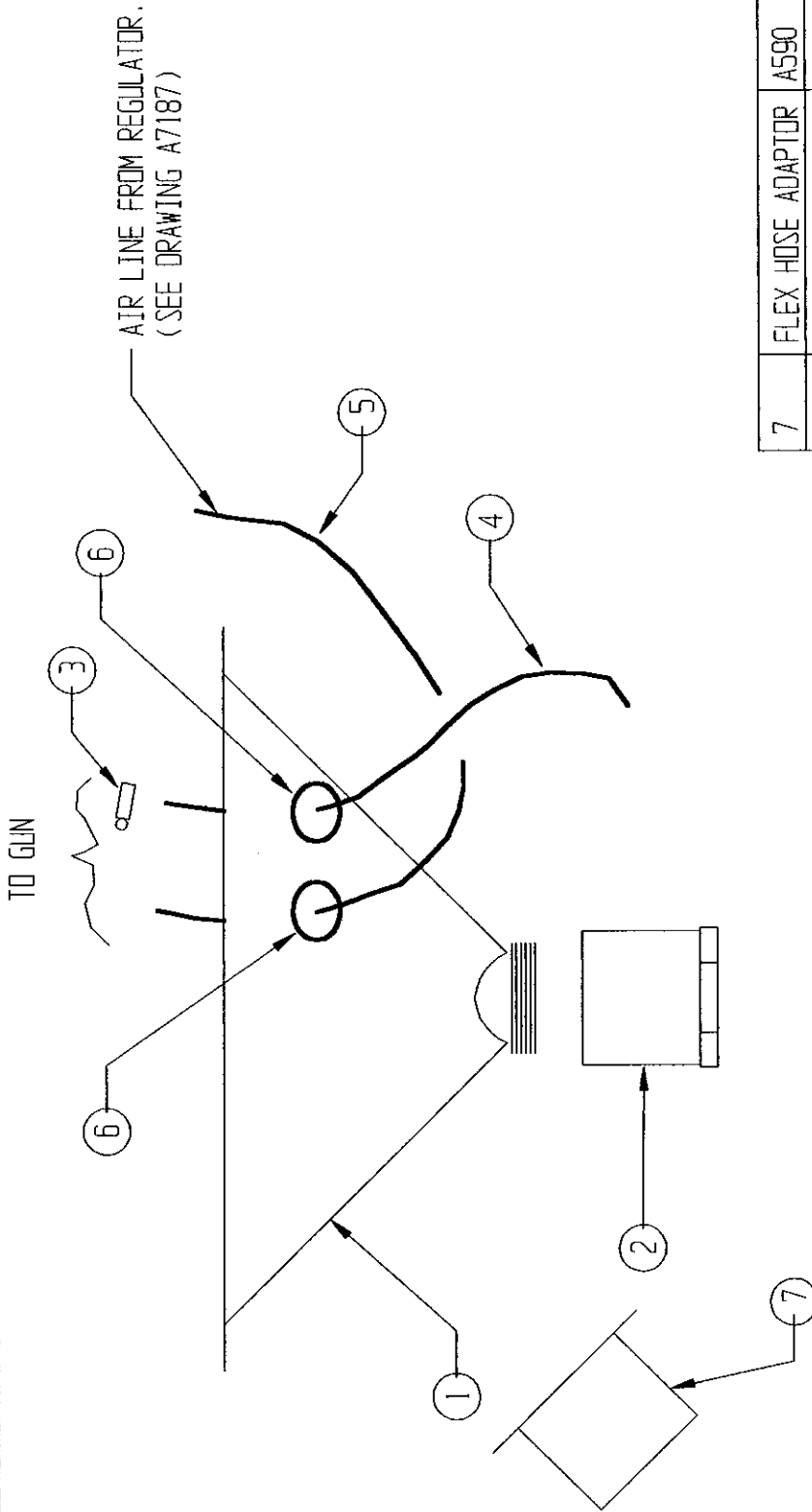

AIR LINE FROM REGULATOR.  
(SEE DRAWING A7187)

TO GUN

-5-

FIGURE 4

ITEM	DESCRIPTION	PART NO.	QTY.
7	FLEX HOSE ADAPTOR	A590	1
6	RUBBER GROMMET	24-050	2
5	AIR HOSE	18-076	5'
4	MEDIA HOSE	18-084	5'
3	HOSE CLAMP	21-031	2
2	CAP		1
1	SUMP	A14086	1

A4098

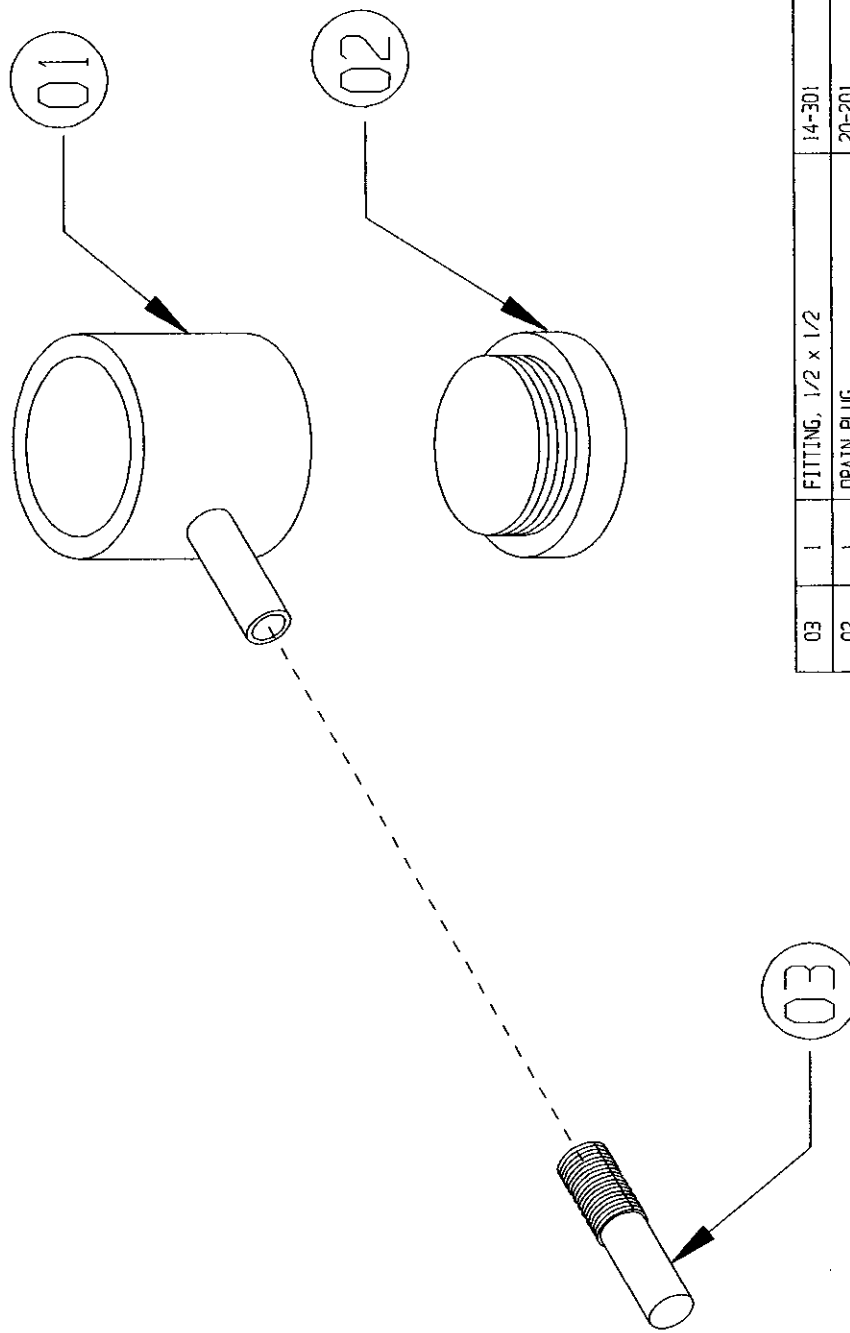

03	1	FITTING, 1/2 x 1/2	14-301
02	1	DRAIN PLUG	20-201
01	1	MEDIA VALVE	20-200

ITEM NO. QTY. DESCRIPTION DWG NO. / MATERIAL  
**LARRY HESS & ASSOCIATES, INC.**  
 SALISBURY NORTH CAROLINA

DESCRIPTION: 2" MEDIA VALVE  
 MATERIAL:

DATE:	06/28/01	SCALE:	1/2" = 1"	JOB NO.:	STD.
BY:	LJF	FUNCTIONAL:		REV. ASY.:	
CHK'D BY:		DATE:			

DRAWING NO.: A4098

**CONFIDENTIAL**

THE DISCLOSURES AND CONTENTS OF THIS DRAWING ARE CONFIDENTIAL AND ARE THE EXCLUSIVE PROPERTY OF BLAST-IT-ALL © A DIV. OF LARRY HESS & ASSOCIATES, INC. THIS DRAWING IS NOT TO BE COPIED OR REPRODUCED WHOLLY OR IN PART WITHOUT WRITTEN PERMISSION OF LARRY HESS & ASSOCIATES, INC.

REV.	DESCRIPTION	BY	DATE

-6-  
 FIGURE 5

SCALE: 3/8"

REV. 01/20/95 BY DEC  
 REV. 07/16/96 BY DEC  
 REV. 09/23/96 BY DEC  
 REV. 10/13/99 BY DEC

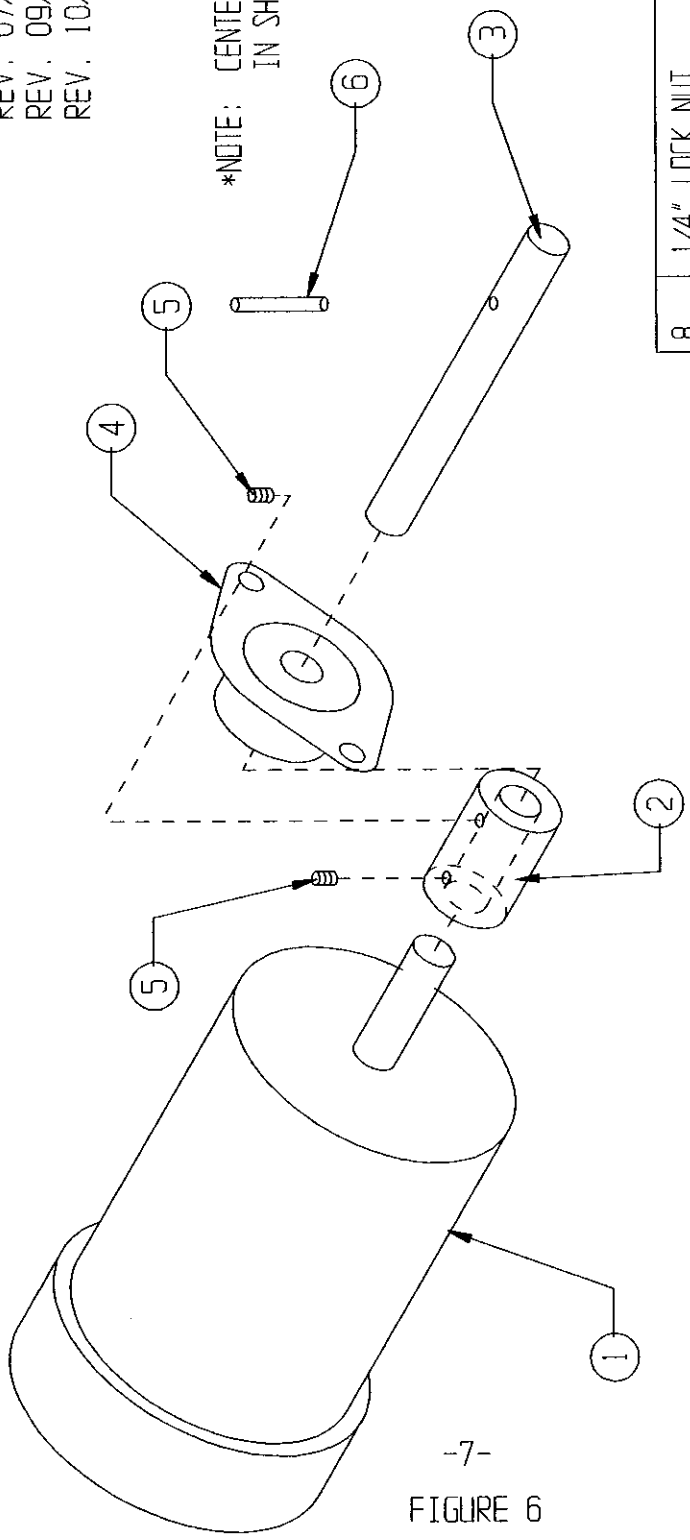

\*NOTE: ITEMS 7 & 8 ARE USED TO MOUNT MOTOR TO MOTOR MOUNTING BRACKET

8	1/4" LOCK NUT	30-503	4
7	BOLT 1/4" x 1" HEX HEAD	30-106	4
6	3/16" ROLL PIN 1-1/2" LG.	010656	1
5	1/4-28 ALLEN HEAD SETSCREW*		2
4	BEARING	010219	1
3	SHAFT	A14091	1
2	COUPLING #6L016 (A14102)	010658	1
1	MOTOR #3M126B	13-909	1
	ITEM DESCRIPTION	PART NO.	QTY.

-7-  
FIGURE 6

A7187

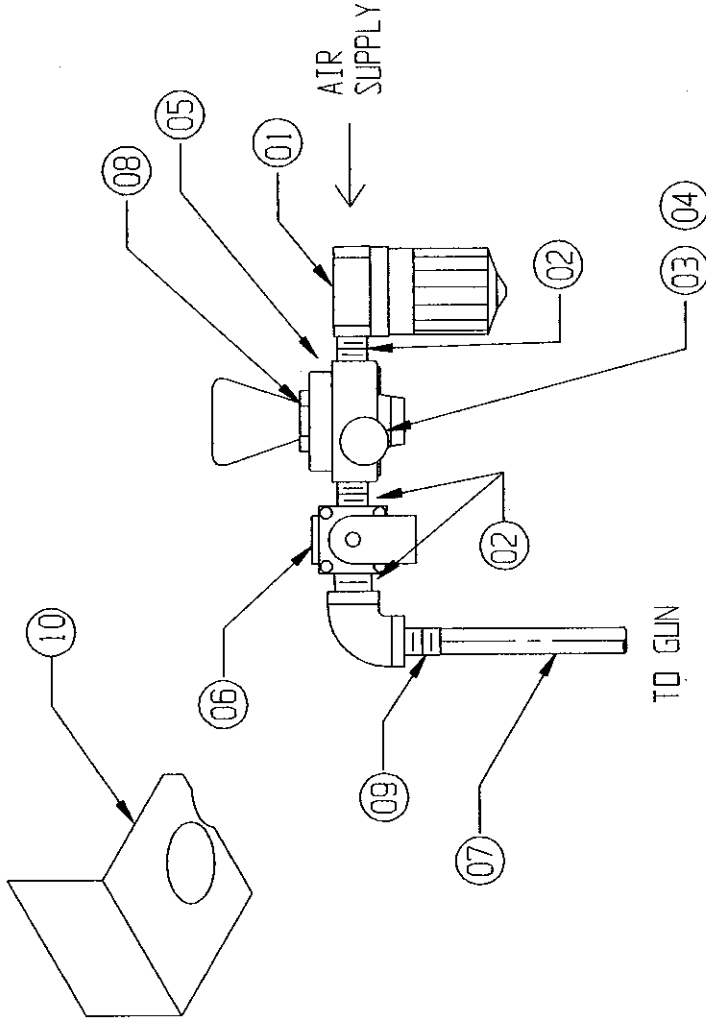

10	1	BRACKET	0105-13
09	1	1/2 x 1/2 BARB FITTING	14-301
08	1	LOCK RING	16-96SLR
07	1	Ø 1/2" AIR HOSE	18-076 x 5' LONG
06	1	1/2" SOLENOID	13-514
05	1	1/2" REGULATOR	16-965
04	1	GAUGE, 1/4"	16-819
03	1	1/4" STREET ELBOW	002301
02	3	1/2" CLOSE NIPPLE	14-378
01	1	FILTER 1/2"	16-966

ITEM NO.	QTY.	DESCRIPTION	DWG NO./ MATERIAL
----------	------	-------------	-------------------

LARRY HESS & ASSOCIATES, INC.,  
 SALISBURY NORTH CAROLINA

DESCRIPTION: LBT-3  
 AIR CONTROLS

MATERIAL:

DATE:	05/25/00	SCALE:	N.T.S.
CHK'D BY:	LJF	JOB NO.:	
DATE:		REV. ASY.:	

REV.	DESCRIPTION	BY	DATE
1	ADD 3 ITEMS	LJF	06/27/01

**CONFIDENTIAL**

THE DISCLOSURES AND CONTENTS OF THIS DRAWING ARE CONFIDENTIAL AND ARE THE EXCLUSIVE PROPERTY OF BLAST-TT-ALL © A DIV. OF LARRY HESS & ASSOCIATES, INC.. THIS DRAWING IS NOT TO BE COPIED OR REPRODUCED WHOLLY OR IN PART WITHOUT WRITTEN PERMISSION OF LARRY HESS & ASSOCIATES, INC..

-8-  
 FIGURE 7

DRAWING NO.: A7187



A5147

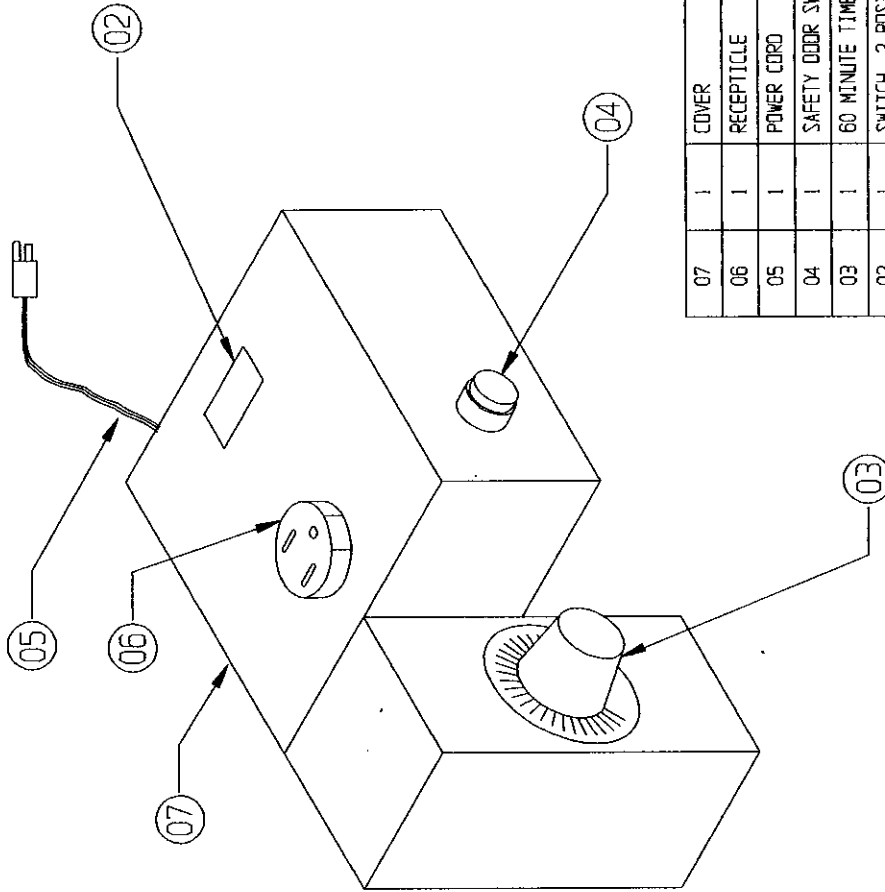

ITEM NO.	QTY.	DESCRIPTION	DWG. NO. / MATERIAL
07	1	COVER	
06	1	RECEPTACLE	
05	1	POWER CORD	13-551
04	1	SAFETY ODOR SWITCH	13-512
03	1	60 MINUTE TIMER	001371
02	1	SWITCH, 2 POSITION	13-655
01	1		

LARRY HESS & ASSOCIATES, INC.  
SALISBURY NORTH CAROLINA

DESCRIPTION: CONTROL ARRANGEMENT  
LBT-3

MATERIAL:  
DRAWING NO.: A5147

**CONFIDENTIAL**

THE DISCLOSURE AND CONTENTS OF THIS DRAWING ARE CONFIDENTIAL AND ARE THE EXCLUSIVE PROPERTY OF BLAST-IT-ALL © A DIV. OF LARRY HESS & ASSOCIATES, INC. THIS DRAWING IS NOT TO BE COPIED OR REPRODUCED WHOLLY OR IN PART WITHOUT WRITTEN PERMISSION OF LARRY HESS & ASSOCIATES, INC.

DATE	BY	DATE
06/28/01 <td>LJF <td></td> </td>	LJF <td></td>	

REV.	DESCRIPTION	BY	DATE

-10-  
FIGURE 9

# LARRY HESS & ASSOCIATES

DESCRIPTION  
WIRING DIAGRAM

DATE  
1/8/92

ENGINEER  
KAS

DWG. NO.  
A8077

REV. BY DEC 07/07/95  
 REV. BY DEC 10/05/95  
 REV. BY DEC 05/14/01  
 REV. BY DEC 11/26/02

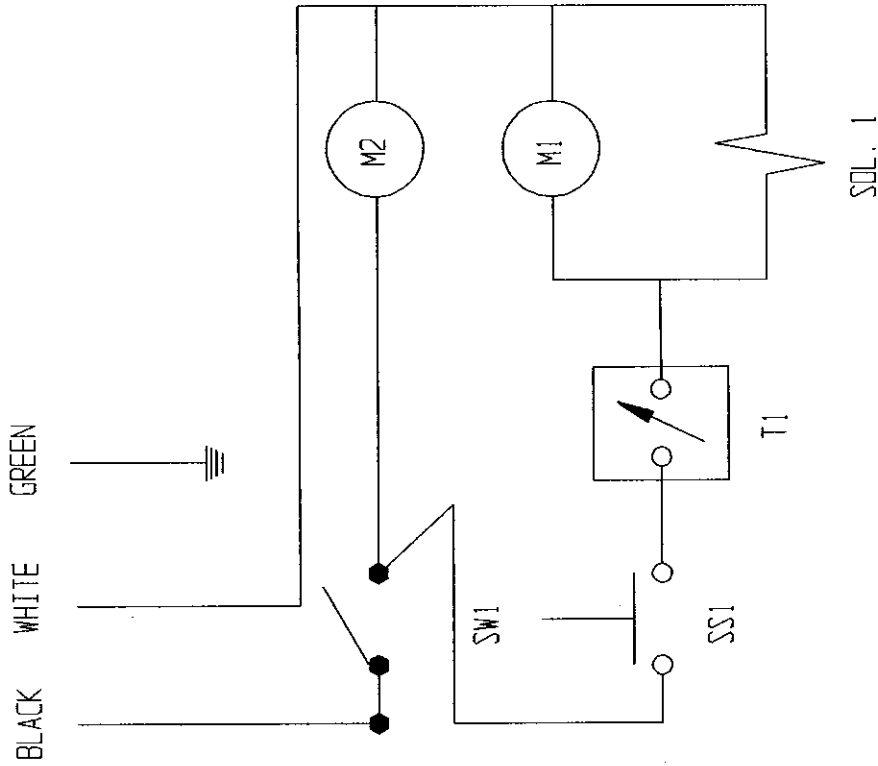

-11-  
FIGURE 10

ITEM	DESCRIPTION	PART NO.	QTY.
SW1	POWER SWITCH	13-655	1
M2	RECLAIMER MOTOR	13-400	1
SOL. 1	SOLENOID	13-513	1
M1	DRIVE MOTOR	13-909	1
T1	60 MIN. TIMER	001371	1
SSI	SAFETY ODOR SWITCH	13-512	1

WIRING DIAGRAM FOR 10" TUMBLE BASKET BLASTER



## WARRANTY

Larry Hess & Associates, Inc. Warrants to the original purchaser the merchandise sold to be free from defects in material and workmanship under normal use and service for a period of one (1) year. Upon prompt notification by the buyer, to LHA, components that are determined by LHA to be defective will be repaired or replaced at no additional charge, F.O.B. our factory.

Manufacturer shall have the right to inspect prior to replacing all merchandise in question.

This warranty does not apply to parts that are directly involved in the blasting operation. Example: gun, gun parts, viewing window, hose, gloves, etc.

Manufacturer shall not be required to pay any removal or installation charges whatsoever under this warranty.

Manufacturer shall not be liable for prospective profits, special or consequential damages, nor shall any recovery of any kind against manufacturer be greater in amount than the cost of repairs of defects in workmanship.

This warranty does not apply to damage caused by accidents, damage in transit, alterations by unauthorized personnel, abuse or damage by flood, fire, or acts of God, nor by artificially generated electric currents or any other cause whatsoever except defects in material or factory workmanship.

In all cases, defective parts must be returned to Larry Hess & Associates, Inc. before credit is issued.

If genuine BLAST-IT-ALL® replacement parts are not used, the warranty is void.

This warranty is in lieu of all other warranties expressed or implied and releases Larry Hess & Associates, Inc. of all other obligations and liabilities whatsoever. This warranty neither assumes nor authorizes any person to assume any obligation other than those specified by this warranty.

## WARNING

**DO NOT USE SAND. SAND WILL CAUSE SILICA DUST, WHICH IS THE CAUSE OF SILICOSIS DISEASE, A CONDITION OF MASSIVE FIBROSIS OF THE LUNGS. THIS STATEMENT INDICATES POTENTIAL PERSONNEL HAZARD. FAILURE TO COMPLY WITH THESE INSTRUCTIONS MAY RESULT IN PERSONAL INJURY.**

BLAST-IT-ALL®  
Larry Hess & Associates, Inc.  
Airport Industrial Park  
185 Piper Lane  
P.O. Box 1615  
Salisbury, NC 28145-1615