

MODEL 3624-12

SKU 009112



INCLUDES THE FOLLOWING:

- ◆ HAND GUN (12 CFM)
- ◆ ALL STEEL CONSTRUCTION
- ◆ LIGHT BOX - 100 WATT FLOOD LIGHT
- ◆ VIEWING GLASS - 12 X 20 TEMPERED
- ◆ GLOVES - SNAP IN (QUICK CHANGE)
- ◆ FRONT OPENING HATCH
- ◆ RIGHT SIDE OPENING DOOR
- ◆ HOPPER DRAIN PLUG
- ◆ HEAVY GRATE WORK SURFACE
- ◆ ECO 100 DUST COLLECTOR



BLAST-IT-ALL®

LARRY HESS & ASSOCIATES, INC.

SALISBURY, NC

TOLL FREE: (800) 535-2612

FAX: (704) 638-9311

www.blast-it-all.com

sales@blast-it-all.com

**100 CFM ECO
CARTRIDGE DUST COLLECTOR**

*** AS SHOWN ON SIDE OF 3624-21**

MODEL 3624-21

SKU 009121

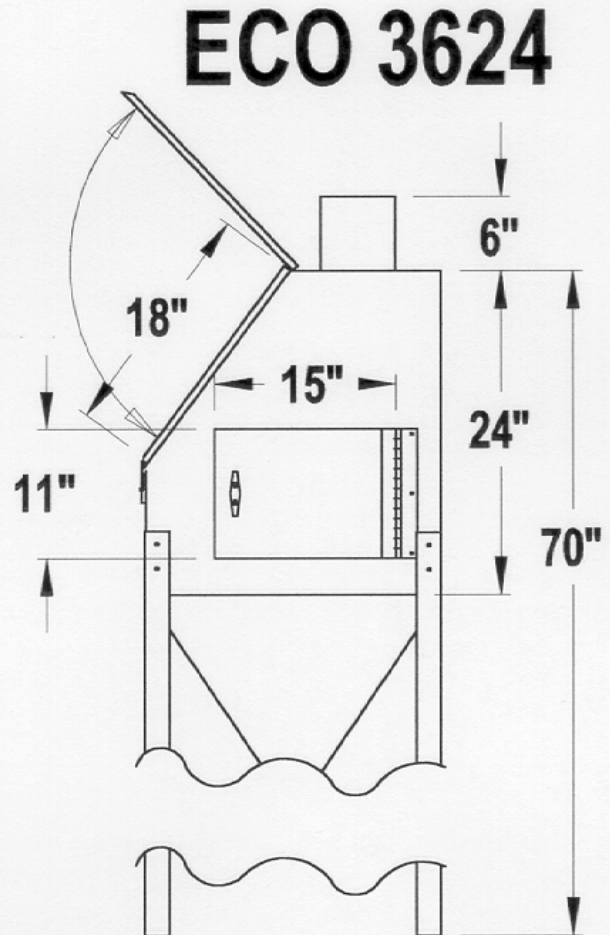

INCLUDES THE FOLLOWING:

- ◆ FOOT CONTROLLED GUN (21 CFM)
- ◆ ALL STEEL CONSTRUCTION
- ◆ LIGHT BOX - 100 WATT FLOOD LIGHT
- ◆ VIEWING GLASS - 12 X 20 TEMPERED
- ◆ GLOVES - SNAP IN (QUICK CHANGE)
- ◆ FRONT OPENING HATCH
- ◆ RIGHT SIDE OPENING DOOR
- ◆ HOPPER DRAIN PLUG
- ◆ HEAVY GRATE WORK SURFACE
- ◆ ECO 100 DUST COLLECTOR

